

Since 1898
CONSEW®

CONSOLIDATED SEWING MACHINE CORP.

PARTS MANUAL FOR Models 695EX & 695HEX

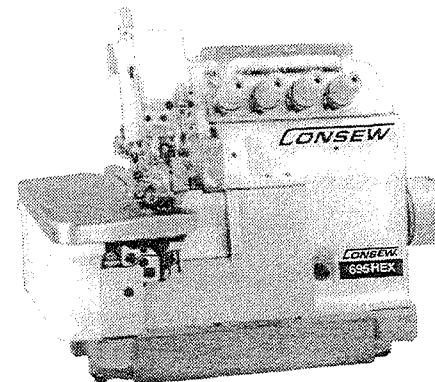
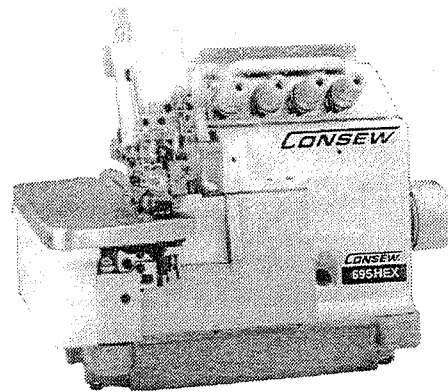

Safety Stitch & Overedging Machines



PARTS MANUAL FOR Models 695EX & 695HEX

TABLE OF CONTENTS

	PAGE
A. MACHINE BED FRAME -----	2-3
B. MACHINE BED FRAME -----	4-5
C. MACHINE BED FRAME -----	6-7
D. MISCELLANEOUS THREAD EYELETS -----	8-9
E. CRANKSHAFT DRIVE MECHANISM -----	10-11
F. THREAD TENSION MECHANISM -----	12-13
G. NEEDLE DRIVE MECHANISM -----	14-15
H. UPPER LOOPER DRIVE MECHANISM -----	16-17
I. LOWER LOOPER DRIVE MECHANISM -----	18-19
J. CHAINSTITCH LOOPER DRIVE MECHANISM -----	20-21
K. CHAINSTITCH LOOPER DRIVE MECHANISM -----	22-23
L. FEED MECHANISM -----	24-25
M. FEED MECHANISM -----	26-27
N. KNIFE DRIVE MECHANISM -----	28-29
O. PRESSER FOOT MECHANISM -----	30-31
P. LUBRICATION MECHANISM -----	32-33
Q. LUBRICATION MECHANISM -----	34-35
R. PARTS FOR SEMI-SUBMERGED INSTALLATIO-----	36-37
S. ACCESSORIES -----	38-39
T. NUMERICAL PARTS-LIST-----	40-43

A. MACHINE BED FRAME -1

Consew 695EX/695HEX

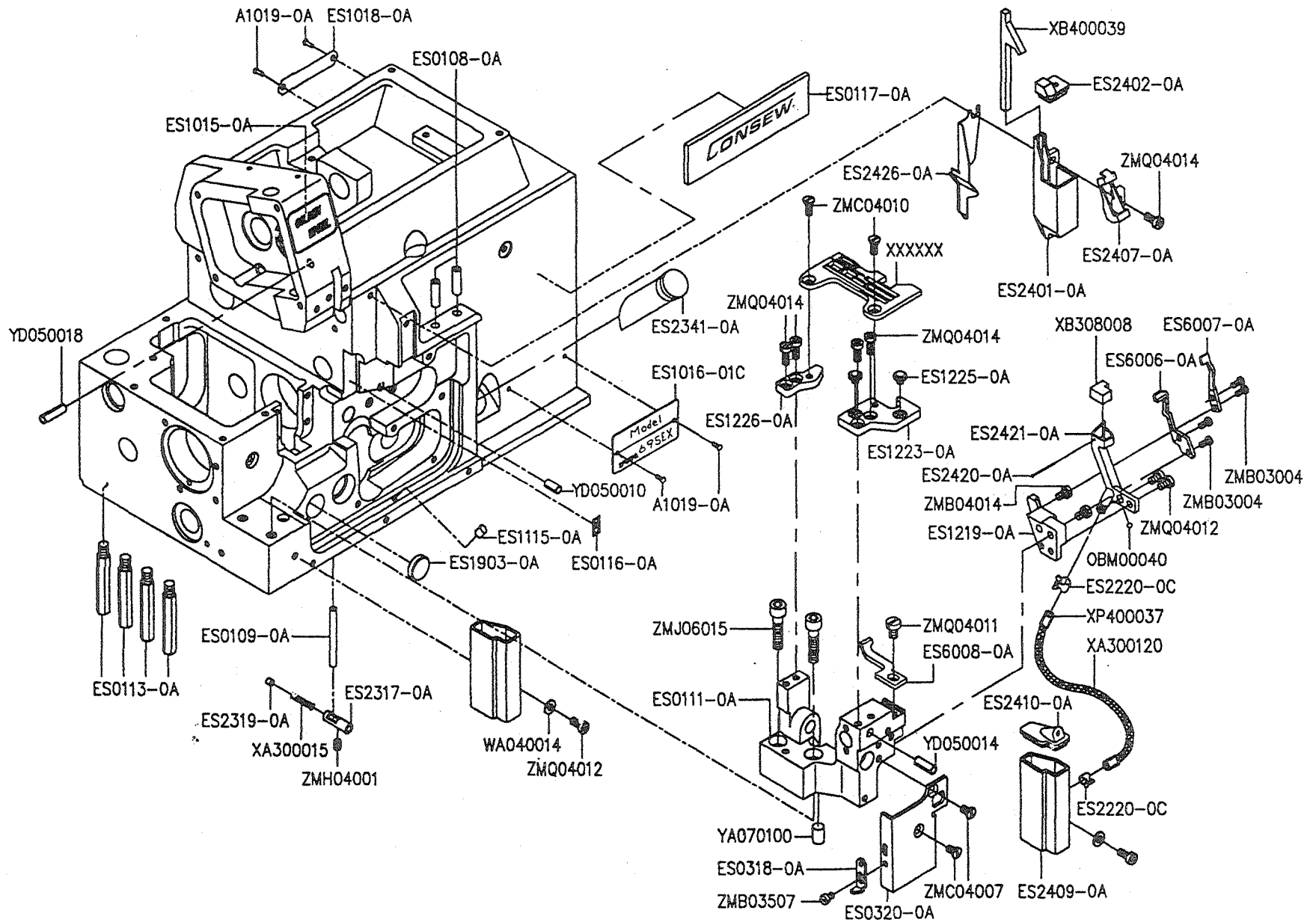

A. MACHINE BED FRAME - 1

Part No	Name of Part	Q'TY	Part No	Name of Part	Q'TY
A1019-0A	PIN -----	4	ES6007-0A	NEEDLE GUARD (FRONT) -	1
ES1015-0B	NAME PLATE -----	1	ES6008-0A	NEEDLE GUARD (FRONT)	1
ES1018-0A	SERIAL NUMBER PLATE	1	OBM00040	PLUG -----	1
ES0108-0A	PIPE -----	2	XA300015	OIL WICK -----	1
ES0109-0A	PIN -----	1	XA300120	OIL WICK -----	1
ES0111-0A	BRACKET ASSEMBLY	1	XB308008	FELT -----	1
ES0113-0A	BED PIN -----	4	XB400039	FELT -----	1
ES0116-0A	OIL MARK -----	1	XP400037	TUBE -----	1
ES0117-0A	MARK -----	3	YA070100	PIN -----	1
ES0318-0A	LATCH -----	1	YD050010	PIN -----	1
ES0320-0A	PLATE -----	1	YD050014	PIN -----	1
ES1016-01C	NAME PLATE -----	1	YD050018	PIN -----	1
ES1115-0A	PLUG FILTER-----	1	ZMB03004	SCREW (M3-0.5x5.7) -----	4
ES1219-0A	BRACKET -----	1	ZMB03507	SCREW (M3.5-0.6x4.5) -----	1
ES1223-0A	BRACKET (FRONT) -----	1	ZMB04014	SCREW (M4-0.7x8.5) -----	2
ES1225-0A	CUSHION RUBBER -----	2	ZMC04007	SCREW (M4-0.7x7.3) -----	2
ES1226-0A	BRACKET (REAR) -----	1	ZMC04010	SCREW (M4-0.7x7.5) -----	2
ES1903-0A	PLUG -----	1	ZMH04001	SCREW (M4-0.7x4) -----	1
ES2220-0C	CLAMP -----	2	ZMJ06015	SCREW (M6-1.0x25) -----	2
ES2317-0A	PIPE -----	1	ZMQ04011	SCREW (M4-0.7x6) -----	1
ES2319-0A	PLUG -----	1	ZMQ04012	SCREW (M4-0.7x12) -----	3
ES2341-0A	OIL LEVER GAUGE -----	1	ZMQ04014	SCREW (M4-0.7x10) -----	5
ES2401-0A	S I L I C O N E O I L	1			
ES2402-0A	COVER -----	1			
ES2407-0A	THREAD GUIDE -----	1			
ES2409-0A	S I L I C O N E O I L	1			
ES2410-0A	COVER -----	1			
ES2420-0A	PIN -----	1			
ES2421-0A	N E E D L E T H R E A D	1			
ES2426-0A	PLATE -----	1			
ES6006-0A	NEEDLE GUARD (REAR)	1			

B. MACHINE BED FRAME -2

Consew 695EX/695HEX

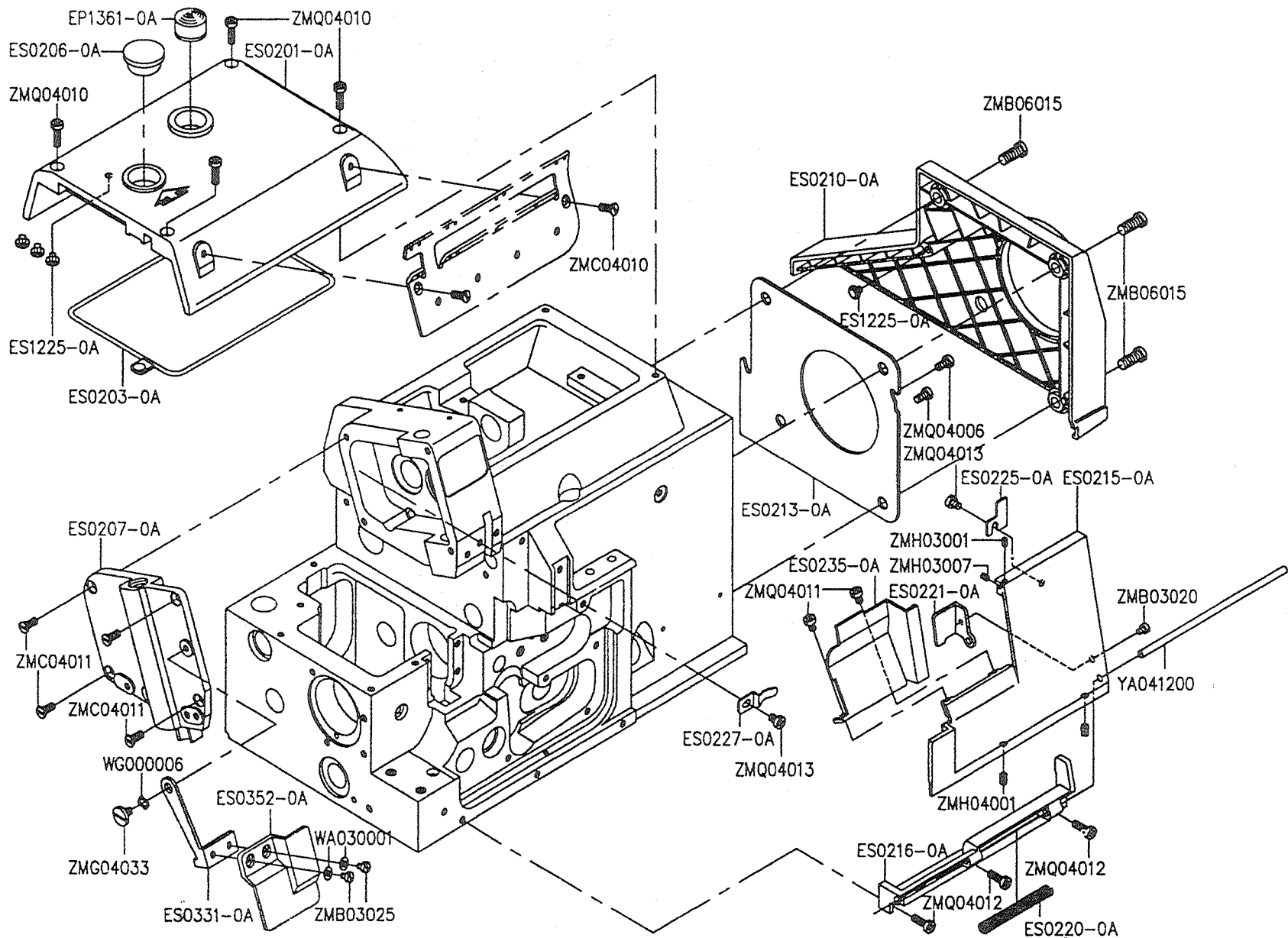

A. MACHINE BED FRAME -2

Part No	Name of Part	Q'TY
EP1361-0A	OIL SIGHT WINDOW -----	1
ES0201-0A	TOP COVER -----	1
ES0203-0A	GASKET -----	1
ES0206-0A	PLUG -----	1
ES0207-0A	SIDE COVER -----	1
ES0210-0A	BELT COVER -----	1
ES0213-0A	FAN COVER -----	1
ES0215-0A	FRONT COVER (RIGHT) -----	1
ES0216-0A	HINGE -----	1
ES0220-0A	SPRING -----	1
ES0221-0A	LATCH -----	1
ES0225-0A	LATCH -----	1
ES0227-0A	FLAT SPRING -----	1
ES0235-0A	FRONT COVER (LEFT) -----	1
ES0331-0A	BRACKET -----	1
ES0352-0A	EYE GUARD -----	1
ES1225-0A	CUSHION RUBBER -----	4
WA030001	WASHER -----	2
WG000006	WASHER -----	1
YA041200	PIN -----	1
ZMB03020	SCREW (M3-0.5x5) -----	1
ZMB03025	SCREW (M3-0.5x6) -----	2
ZMB06015	SCREW (M6-1.0x14) -----	3
ZMC04010	SCREW (M4-0.7x7.5) -----	2
ZMC04011	SCREW (M4-0.7x10) -----	4
ZMG04033	SCREW (M4-0.7x3.8) -----	1
ZMH03001	SCREW (M3-0.5x4) -----	1
ZMH03007	SCREW (M3-0.5x12) -----	1
ZMH04001	SCREW (M4-0.7x4) -----	2
ZMQ04006	SCREW (M4-0.7x8) -----	2
ZMQ04011	SCREW (M4-0.7x6) -----	2
ZMQ04012	SCREW (M4-0.7x12) -----	3
ZMQ04013	SCREW (M4-0.7x5) -----	2
ZMQ04010	SCREW (M4-0.7x16) -----	4

C. MACHINE BED FRAME - 3

Consew 695EX/695HEX

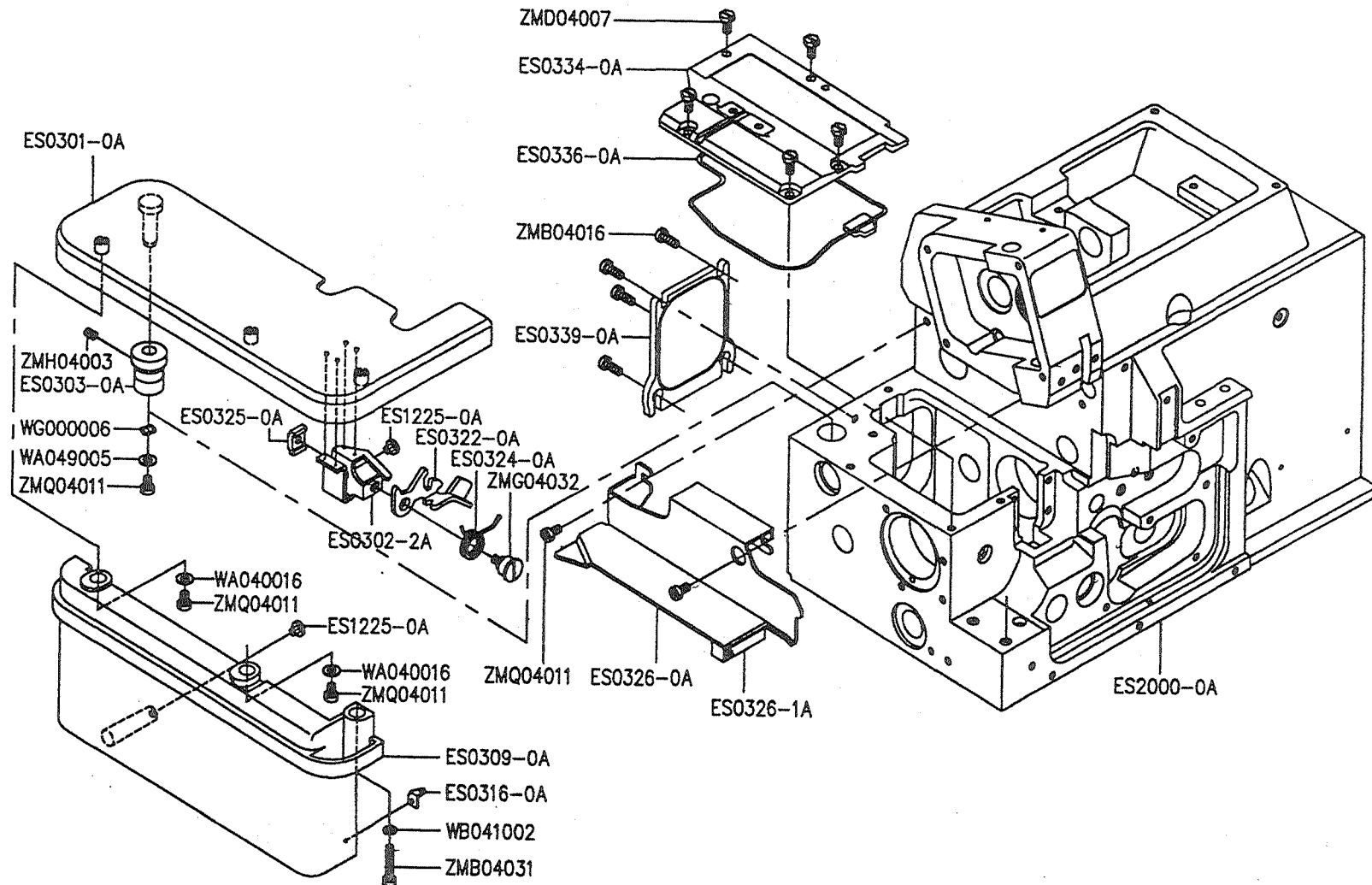

A. MACHINE BED FRAME - 3

Part No	Name of Part	Q'TY
ES0301-0A	CLOTH PLATE (WIDE) -----	1
ES0302-2A	PLATE -----	1
ES0303-0A	BUSHING -----	1
ES0309-0A	SIDE COVER -----	1
ES0316-0A	LATCH -----	1
ES0322-0A	LEVER -----	1
ES0324-0A	SPRING -----	1
ES0325-0A	BRACKET -----	1
ES0326-0A	FABRIC GUARD -----	1
ES0326-1A	SWAB -----	1
ES0334-0A	BED COVER PLATE ASSEMBLY ----	1
ES0336-0A	GASKET -----	1
ES0339-0A	COVER PLATE -----	1
ES1225-0A	CUSHION RUBBER -----	2
ES2000-0A	MACHINE BED COMPLETE -----	1
WA040016	WASHER -----	2
WA049005	WASHER -----	1
WB041002	SPRING WASHER -----	1
WG000006	WASHER -----	1
ZMB04016	SCREW (M4-0.7x10) -----	4
ZMB04031	SCREW (M4-0.7x20) -----	1
ZMD04007	SCREW (M4-0.7x8) -----	4
ZMG04032	SCREW (M4-0.7x5) -----	1
ZMH04003	SCREW (M4-0.7x5) -----	1
ZMQ04011	SCREW (M4-0.7x6) -----	5

D. MISCELLANEOUS THREAD EYELETS

Consew 695EX/695HEX

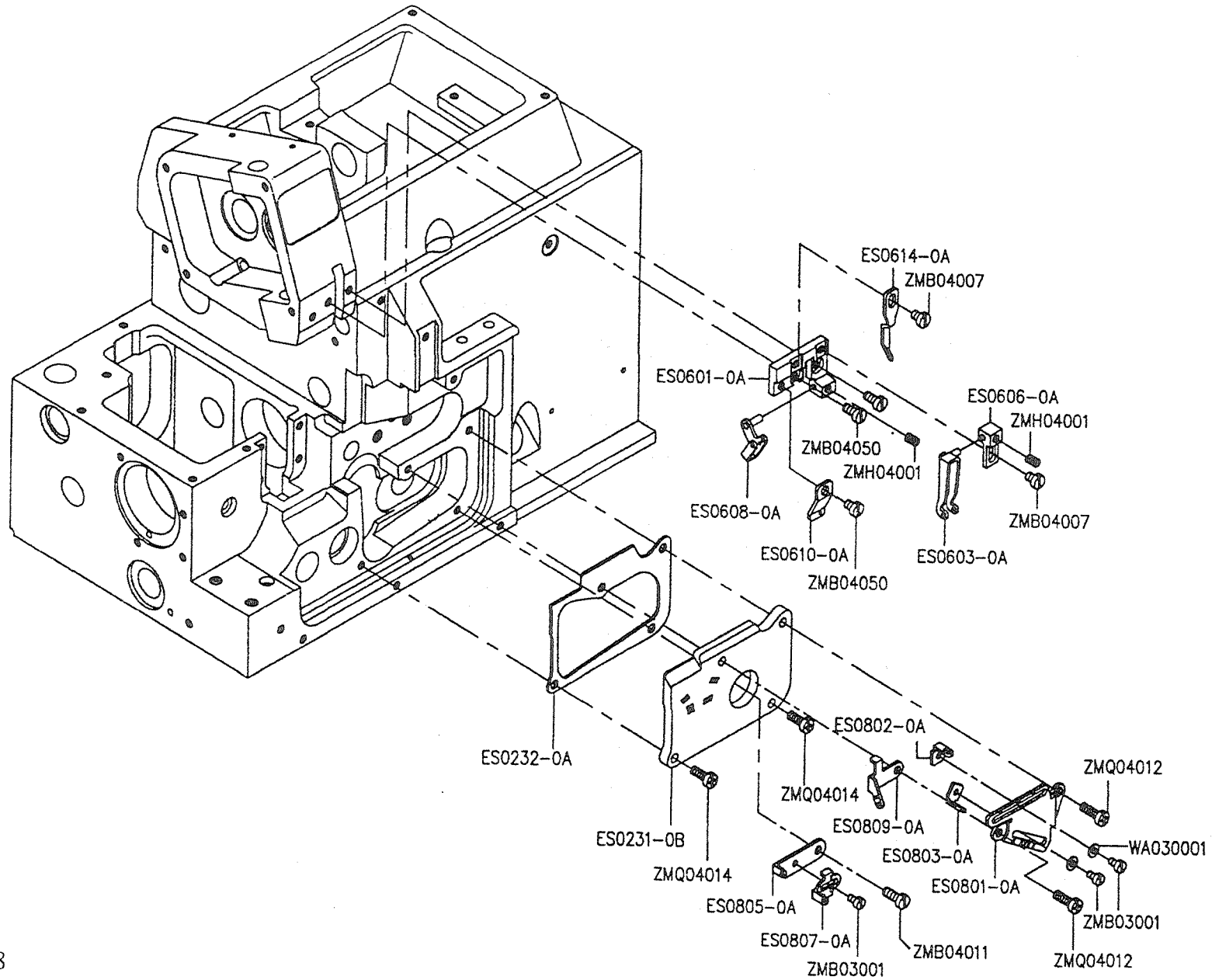

D. MISCELLANEOUS THREAD EYELETS

Part No	Name of Part	Q'TY
ES0231-0B	COVER -----	1
ES0232-0A	GASKET-----	1
ES0601-0A	BRACKET -----	1
ES0603-0A	THREAD GUIDE -----	1
ES0606-0A	BRACKET -----	1
ES0608-0A	THREAD GUIDE -----	1
ES0610-0A	THREAD GUIDE -----	1
ES0614-0A	THREAD GUIDE -----	1
ES0801-0A	BRACKET -----	1
ES0802-0A	THREAD GUIDE -----	1
ES0803-0A	THREAD GUIDE -----	1
ES0805-0A	THREAD GUIDE -----	1
ES0807-0A	THREAD GUIDE -----	1
ES0809-0A	THREAD GUIDE -----	1
WA030001	WASHER -----	2
ZMB03001	SCREW (M3-0.5x4) -----	3
ZMB04007	SCREW (M4-0.7x5) -----	2
ZMB04011	SCREW (M4-0.7x8) -----	1
ZMB04050	SCREW (M4-0.7x8) -----	3
ZMH04001	SCREW (M4-0.7x4) -----	2
ZMQ04012	SCREW (M4-0.7x12) -----	2
ZMQ04014	SCREW (M4-0.7x10) -----	2

E. CRANKSHAFT DRIVE MECHANISM

Consew 695EX/695HEX

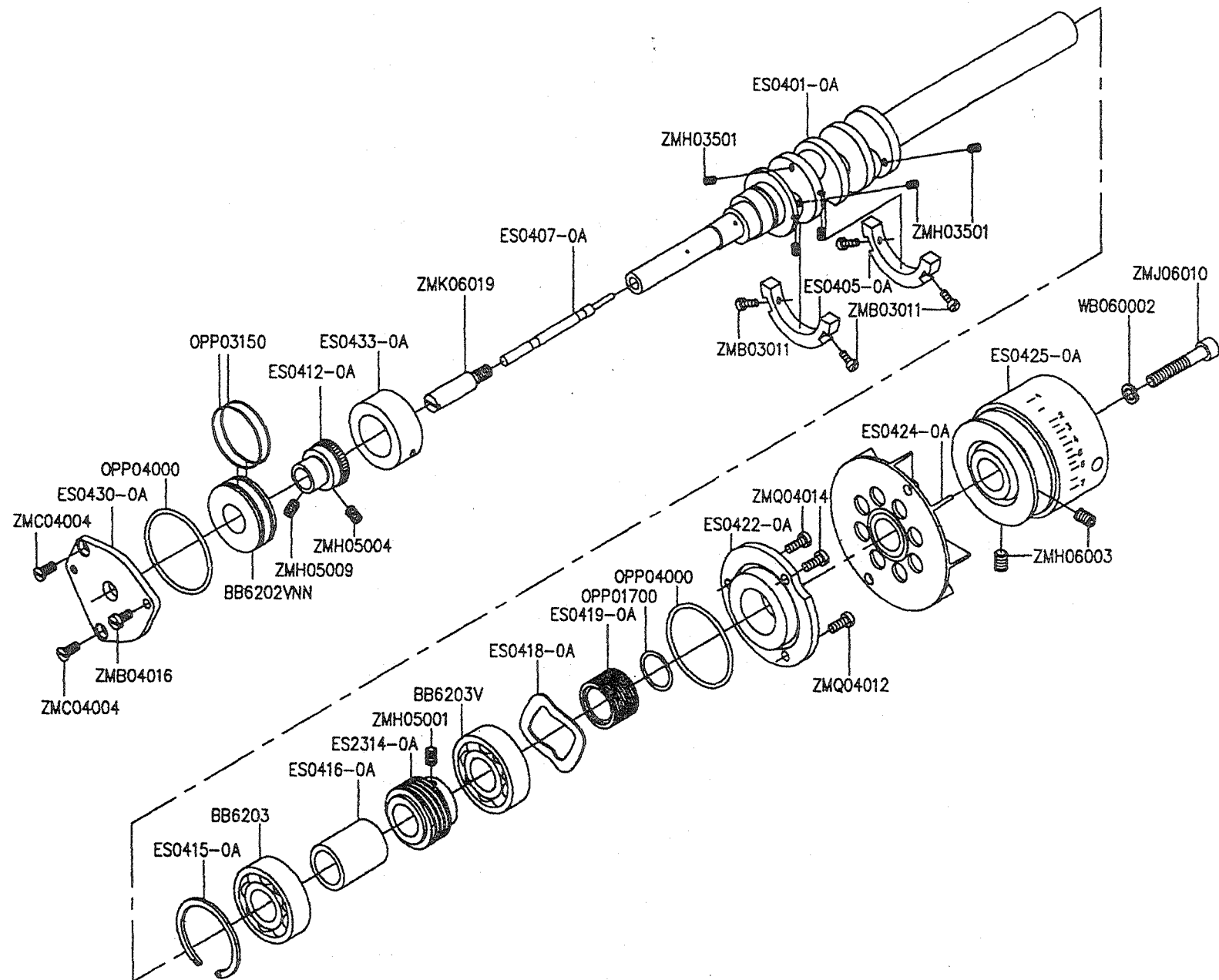

E. CRANKSHAFT DRIVE MECHANISM

Part No.	Name of Part	Q'TY
BB6202VNN	BALL BEARING -----	1
BB6203	BALL BEARING -----	1
BB6203V	BALL BEARING -----	1
ES0401-0A	CRANKSHAFT -----	1
ES0405-0A	BALANCE WEIGHT -----	2
ES0407-0A	PIN -----	1
ES0412-0A	BALL BEARING COMPLETE -----	1
ES0415-0A	RING -----	1
ES0416-0A	RING -----	1
ES0418-0A	WASHER -----	1
ES0419-0A	OIL SEAL -----	1
ES0422-0A	BALL BEARING RETAINER -----	1
ES0424-0A	FAN COMPLETE -----	1
ES0425-0A	MACHINE PULLEY -----	1
ES0430-0A	COVER -----	1
ES0433-0A	RING -----	1
ES2314-0A	WORM -----	1
OPP01700	O RING -----	1
OPP03150	O RING -----	2
OPP04000	O RING -----	1
WB060002	SPRING WASHER -----	1
ZMB03011	SCREW (M3-0.5x8) -----	4
ZMB04016	SCREW (M4-0.7x10) -----	1
ZMC04004	SCREW (M4-0.7x10) -----	2
ZMH03501	SCREW (M3.5-0.6x3) -----	5
ZMH05001	SCREW (M5-0.8x5) -----	1
ZMH05004	SCREW (M5-0.8x10) -----	1
ZMH05009	SCREW (M5-0.8x5) -----	1
ZMH06003	SCREW (M5-1.0x8) -----	2
ZMJ06010	SCREW (M6-1.0x35) -----	1
ZMK06019	SCREW (M4-1.0x8) -----	1
ZMQ04014	SCREW (M4-0.7x10) -----	3

F. THREAD TENSION MECHANISM

Consew 695EX/695HEX

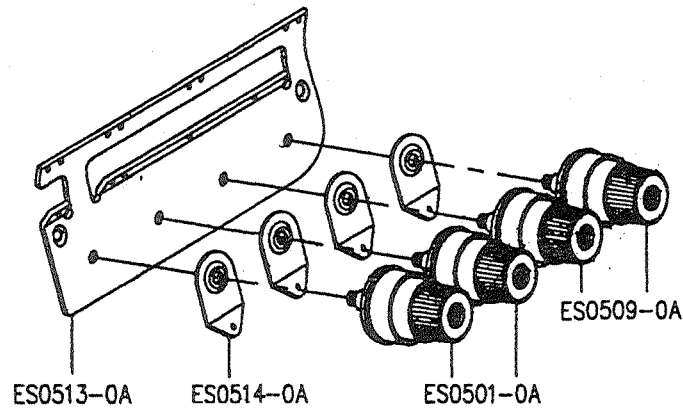
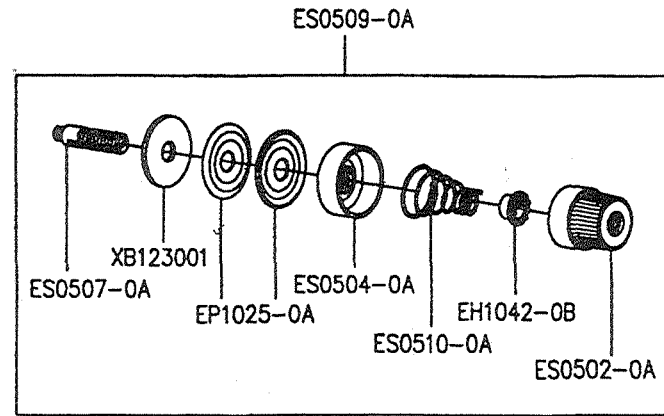
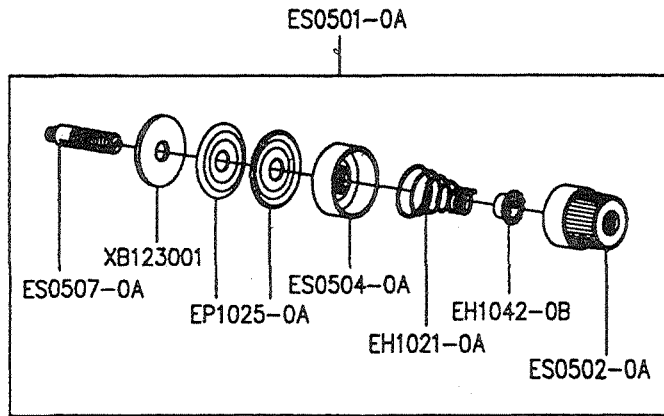





F. THREAD TENSION MECHANISM

Part No	Name of Part	Q'TY
EH1021-0A	SPRING (HEAVY) -----	2
EP1025-0A	TENSION DISC -----	8
ES0501-0A	THREAD TENSION COMPLETE -----	2
ES0502-0A	POST NUT -----	4
EH1042-0B	SPRING BUSHING -----	4
ES0504-0A	CUP -----	4
ES0507-0A	SCREW STUD -----	4
ES0509-0A	THREAD TENSION COMPLETE -----	2
ES0510-0A	SPRING (MEDIUM) -----	2
ES0513-0A	THREAD EYELET -----	1
ES0514-0A	TENSION GUIDE -----	4
XB123001	FELT -----	4

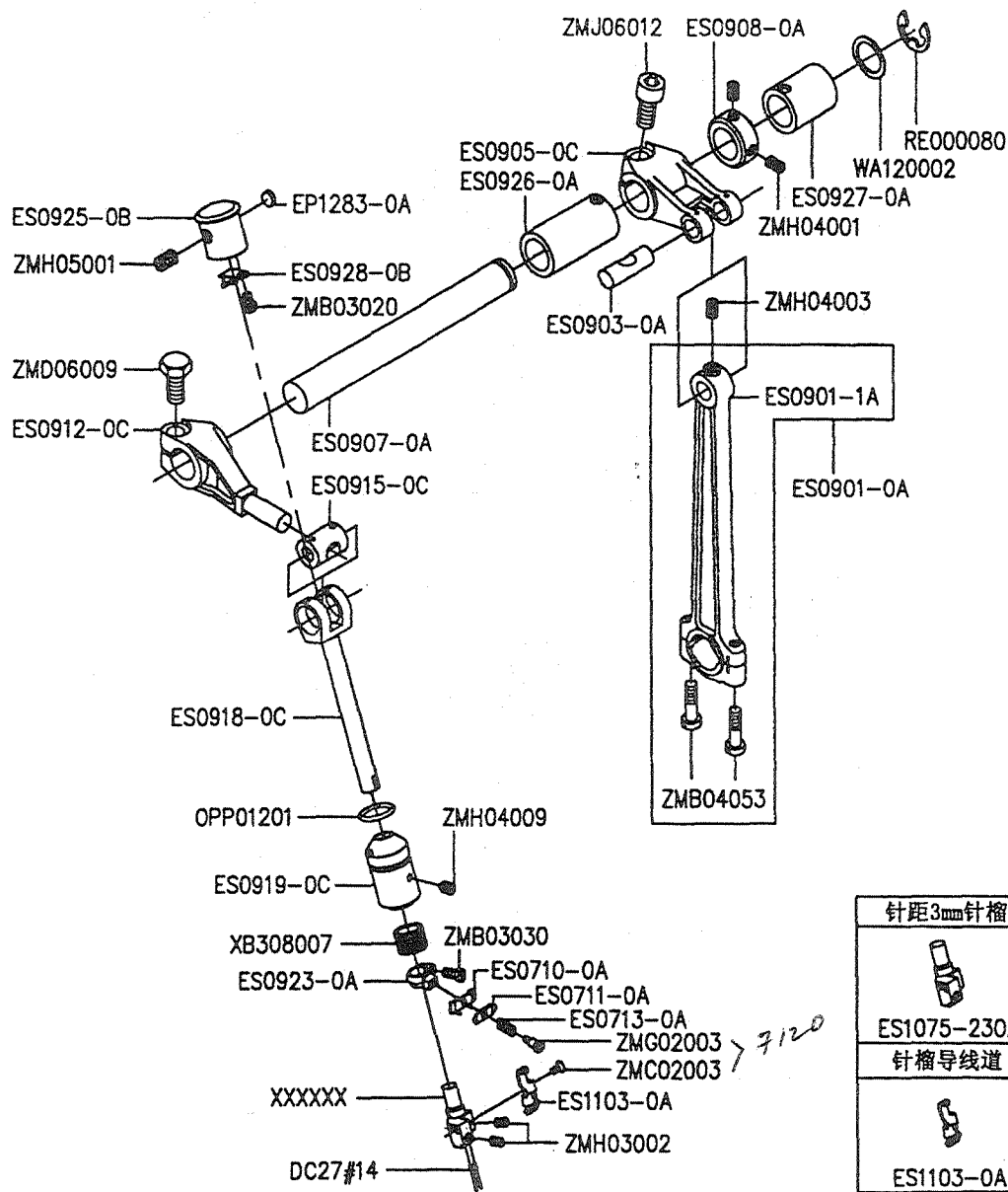
G. NEEDLE DRIVE MECHANISM

Consew 695EX/695HEX



针距3mm针榴	针距5mm针榴
	
ES1075-230A	ES1075-250A
针榴导线道	针榴导线道
	
ES1103-0A	ES1103-0A

695HEX - 142 X 5

G、CS-2500 針棒傳動機構 NEEDLE DRIVE MECHANISM

Part No	Name of Part	Q'TY	Notes
DC27#14	NEEDLE -----	2	
EP1283-0A	RUBBER SEAT -----	1	
ES0710-0A	BRACKET -----	1	
ES0711-0A	THREAD RETAINER -----	1	
ES0713-0A	SPRING -----	1	
ES0901-0A	CONNECTION -----	1	
ES0901-1A	CONNECTION -----	1	
ES0903-0A	PIN -----	1	
ES0905-0C	CRANK -----	1	
ES0907-0A	SHAFT -----	1	
ES0908-0A	COLLAR -----	1	
ES0912-0C	LEVER -----	1	
ES0915-0C	SHAFT -----	1	
ES0918-0C	NEEDLE BAR -----	1	
ES0919-0C	BUSHING -----	1	
ES0923-0A	RING -----	1	
ES0925-0B	PLUG -----	1	
ES0926-0A	BUSHING -----	1	
ES0927-0A	BUSHING -----	1	
ES0928-0B	PLATE -----	1	
ES1075-230A	NEEDLE HOLDER ASSEMBLY ---	1	3mm
ES1075-250A	NEEDLE HOLDER ASSEMBLY ---	1	5mm
ES1103-0A	THREAD GUIDE -----	1	
OPP01201	O RING -----	1	
RE000080	E RING -----	1	
WA120002	WASHER -----	1	
XB308007	FELT -----	1	
ZMB03020	SCREW (M3-0.5x5) -----	1	
ZMB03030	SCREW (M3-0.5x5.5) -----	1	
ZMB04053	SCREW (M4-0.7x16) -----	2	
ZMC02003	SCREW (M2-0.4x5) -----	1	
ZMD06009	SCREW (M6-1.0x12) -----	1	
ZMG02003	SCREW (M2-0.4x3) -----	1	
ZMH03002	SCREW (M3-0.5x3) -----	2	
ZMH04001	SCREW (M4-0.7x4) -----	2	
ZMH04003	SCREW (M4-0.7x5) -----	1	
ZMH04009	SCREW (M4-0.7x5) -----	1	
ZMH05001	SCREW (M5-0.8x5) -----	1	
ZMJ06012	SCREW (M6-0.75x12) -----	1	

H. UPPER LOOPER DRIVE MECHANISM

Consew 695EX/695HEX

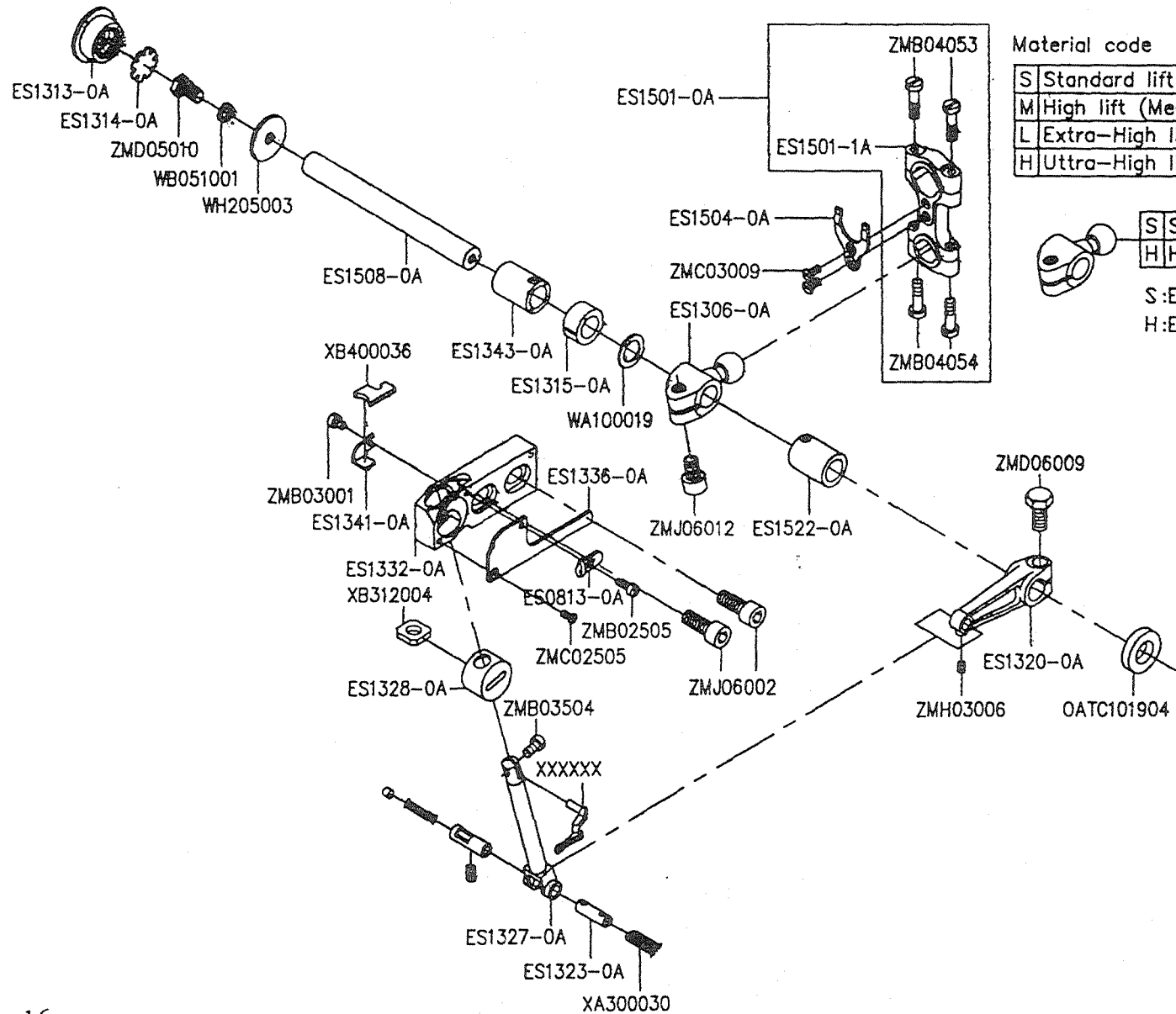

Material code

S	Standard lift (Extra-light-medium)
M	High lift (Medium-heavy)
L	Extra-High lift (Heavy-extra-heavy)
H	Ultra-High lift (Extra-heavy)

S	Standard lift
H	High lift . Extra-high lift

S:ES1306-0A
H:ES1307-0A

H. UPPER LOOPER DRIVE MECHANISM

Part No	Name of Part	Q'TY
ES0813-0A	TENSION GUIDE -----	1
ES1306-0A	CARNK -----	1
ES1307-0A	CARNK -----	1
ES1313-0A	PLUG -----	1
ES1314-0A	FILTER -----	1
ES1315-0A	SPACER -----	1
ES1320-0A	LEVER -----	1
ES1323-0A	PIN -----	1
ES1327-0A	UPPER LOOPER HOLDER -----	1
ES1328-0A	GUIDE/UPPER LOOPER HOLDER ----	1
ES1332-0A	BASE/UPPER LOOPER HOLDER ----	1
ES1336-0A	COVER -----	1
ES1341-0A	PLATE -----	1
ES1343-0A	BUSHING -----	1
ES1501-0A	CONNECTION -----	1
ES1501-1A	CONNECTION -----	1
ES1504-0A	GUIDE -----	1
ES1508-0A	SHAFT -----	1
ES1522-0A	BUSHING -----	1
OATC101904	OIL SEAL -----	1
WA100019	WASHER -----	1
WB051001	SPRIN WASHER -----	1
WH205003	WASHER -----	1
XA300030	OIL WICK -----	1
XB312004	FELT -----	1
XB400036	FELT -----	1
ZMB02505	SCREW (M2.5-0.45x6) -----	1
ZMB03001	SCREW (M3-0.5x4) -----	1
ZMB03504	SCREW (M3.5-0.6x6) -----	1
ZMB04053	SCREW (M4-0.7x16) -----	2
ZMB04054	SCREW (M4-0.7x13) -----	2
ZMC02505	SCREW (M2.5-0.45x4) -----	1
ZMC03009	SCREW (M3-0.5x5) -----	2
ZMD05010	SCREW (M5-0.8x10) -----	1
ZMD06009	SCREW (M6-1.0.7x12) -----	1
ZMH03006	SCREW (M3-0.5x4) -----	1
ZMJ06002	SCREW (M6-1.0x15) -----	2
ZMJ06012	SCREW (M6-0.75x12) -----	1

I. LOWER LOOPER DRIVE MECHANISM

Consew 695EX/695HEX

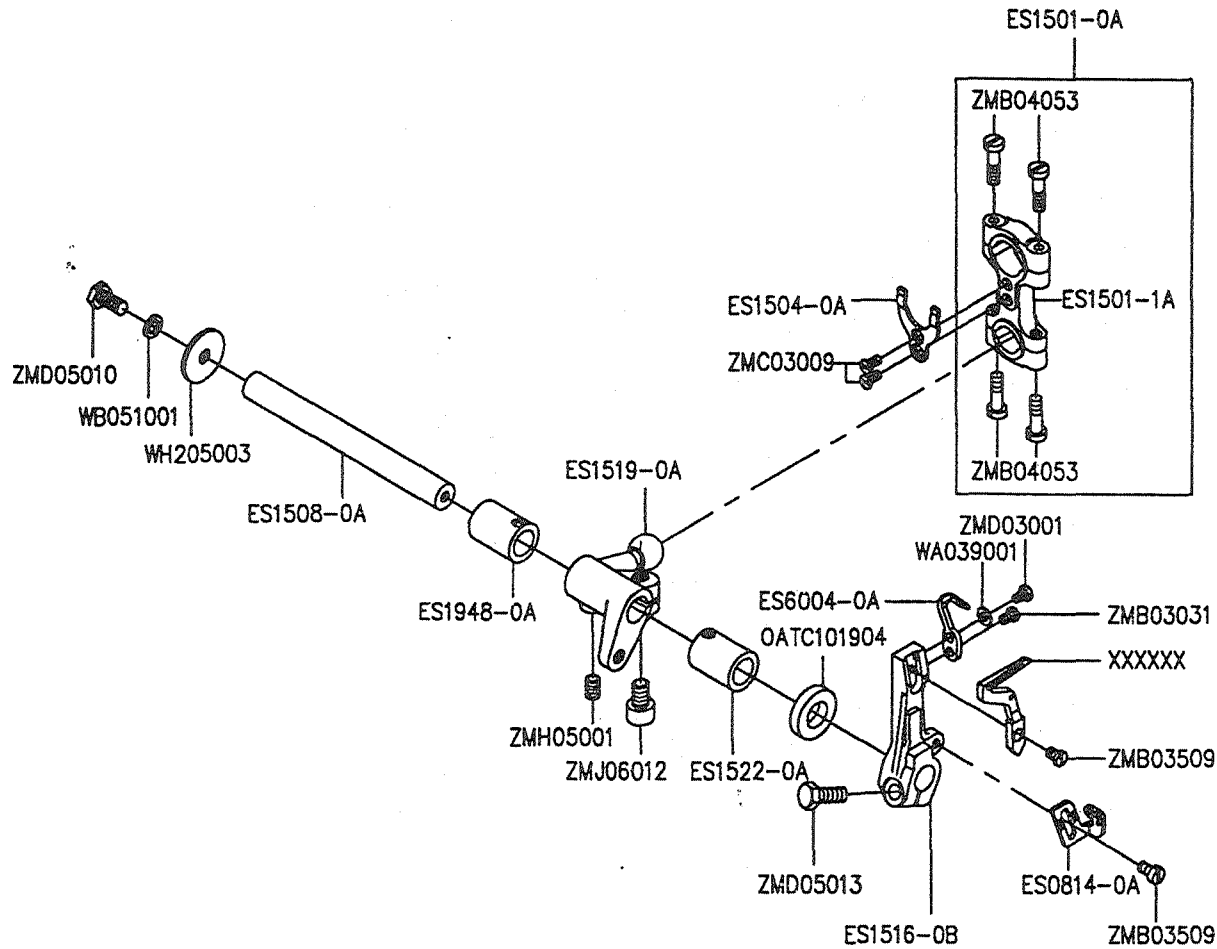

I. LOWER LOOPER DRIVE MECHANISM

Part No	Name of Part	Q'TY
ES0814-0A	TENSION GUIDE -----	1
ES1501-0A	CONNECTION -----	1
ES1501-1A	CONNECTION -----	1
ES1504-0A	GUIDE -----	1
ES1508-0A	SHAFT -----	1
ES1516-0B	SHAFT -----	1
ES1519-0A	CRANK -----	1
ES1522-0A	BUSHING -----	1
ES1948-0A	BUSHING -----	1
ES6004-0A	NEEDLE GUARD (REAR) ----	1
OATC10190	OIL SEAL -----	1
WA039001	WASHER -----	1
WB051001	SPRING WASHER -----	1
WH205003	WASHER -----	1
ZMB03031	SCREW (M3-0.5x2.5) -----	1
ZMB03509	SCREW (M3.5-0.6x6) -----	2
ZMB04053	SCREW (M4-0.7x16) -----	4
ZMC03009	SCREW (M3-0.5x5) -----	2
ZMD03001	SCREW (M3-0.5x5) -----	1
ZMD05010	SCREW (M5-0.8x10) -----	1
ZMD05013	SCREW (M5-0.8x13) -----	1
ZMH05001	SCREW (M5-0.8x5) -----	1
ZMJ06012	SCREW (M6-0.75x12) -----	1

J. CHAINSTITCH LOOPER DRIVE MECHANISM

Consew 695EX/695HEX

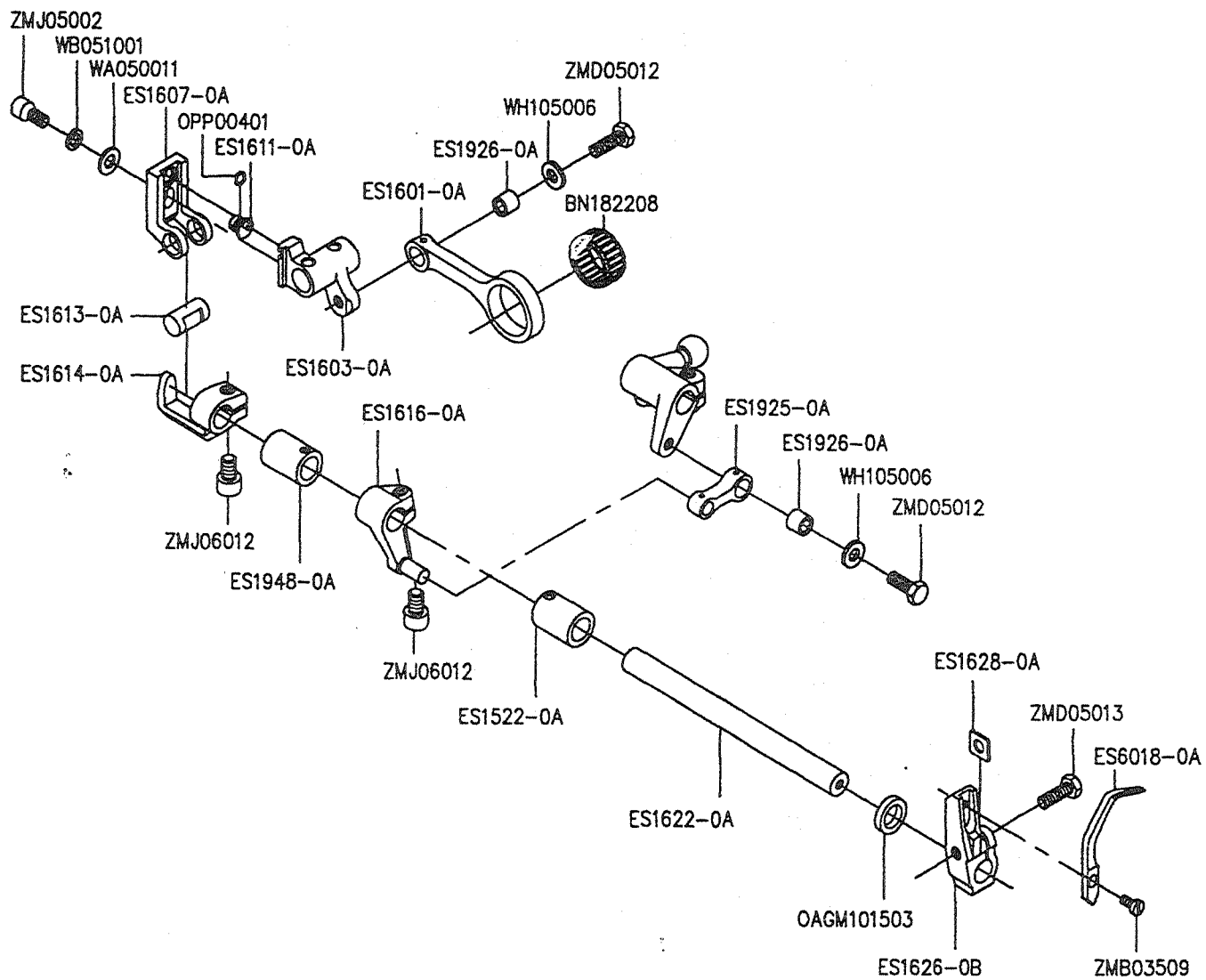

J. CHAINSTITCH LOOPER DRIVE MECHANISM

Part No	Name of Part	Q'TY
BN182208	NEEDLE BEARING -----	1
ES1522-0A	BUSHING -----	1
ES1601-0A	CONNECTION -----	1
ES1603-0A	CRANK -----	1
ES1607-0A	SLIDER -----	1
ES1611-0A	PIN -----	1
ES1613-0A	SHAFT -----	1
ES1614-0A	HOLDER -----	1
ES1616-0A	CRANK -----	1
ES1622-0A	SHAFT -----	1
ES1626-0B	LOOPER HOLDER -----	1
ES1628-0A	SPACER -----	1
ES1925-0A	LINK -----	1
ES1926-0A	BUSHING -----	1
ES1948-0A	BUSHING -----	1
ES6018-0A	LOWER LOOPER -----	1
OAGM1015	OIL SEAL -----	1
OPP00401	O RING -----	1
WA050011	WASHER -----	1
WB051001	SPRING WASHER -----	1
WH105006	WASHER -----	2
ZMB03509	SCREW (M3.5-0.6x6) -----	1
ZMD05012	SCREW (M5-0.8x13) -----	2
ZMD05013	SCREW (M5-0.8x13) -----	1
ZMJ05002	SCREW (M5-0.8x12) -----	1
ZMJ06012	SCREW (M6-0.75x12) -----	2

K. CHAINSTITCH LOOPER DRIVE MECHANISM *Consew 695EX/695HEX*

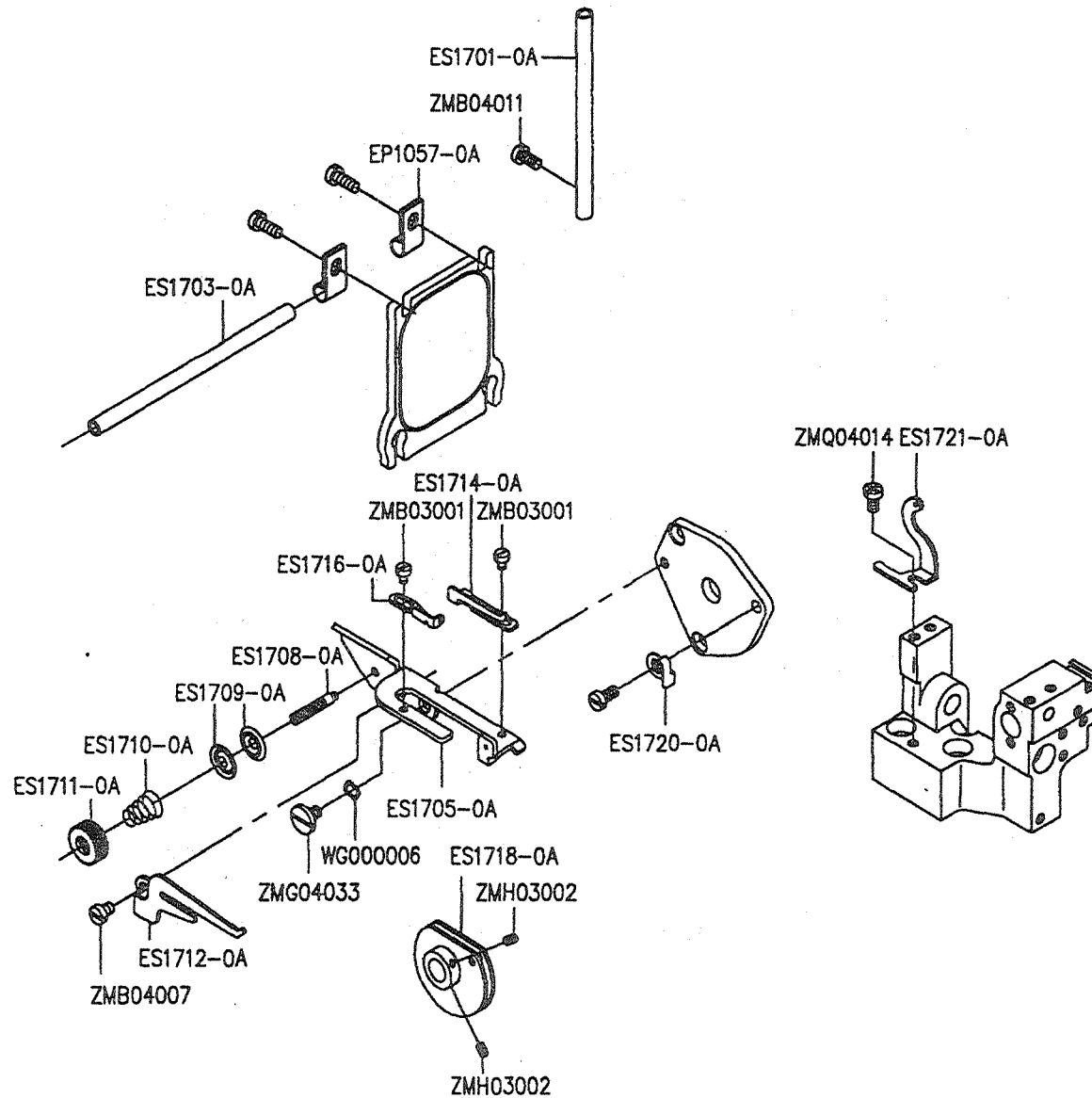

K. CHAINSTITCH LOOPER DRIVE MECHANISM

Part No	Name of Part	Q'TY
EP1057-0A	HOLDER -----	3
ES1701-0A	THREAD GUIDE -----	1
ES1703-0A	THREAD GUIDE -----	1
ES1705-0A	BRACKET -----	1
ES1708-0A	SCREW -----	1
ES1709-0A	TENSION DISC -----	2
ES1710-0A	SPRING -----	1
ES1711-0A	KNOB -----	1
ES1712-0A	THREAD GUIDE -----	1
ES1714-0A	THREAD GUIDE -----	1
ES1716-0A	THREAD GUIDE -----	1
ES1718-0A	LOOPER THREAD TAKEUP ASSEMBLY ----	1
ES1720-0A	SPRING -----	1
ES1721-0A	THREAD GUIDE -----	1
WG000006	WASHER -----	1
ZMB03001	SCREW (M3-0.5x4) -----	2
ZMB04007	SCREW (M4-0.7x5) -----	1
ZMB04011	SCREW (M4-0.7x8) -----	1
ZMG04033	SCREW (M4-0.7x3.8) -----	1
ZMH03002	SCREW (M3-0.5x3) -----	2
ZMQ04014	SCREW (M4-0.7x10)- -----	1

L. FEED MECHANISM

Consew 695EX/695HEX

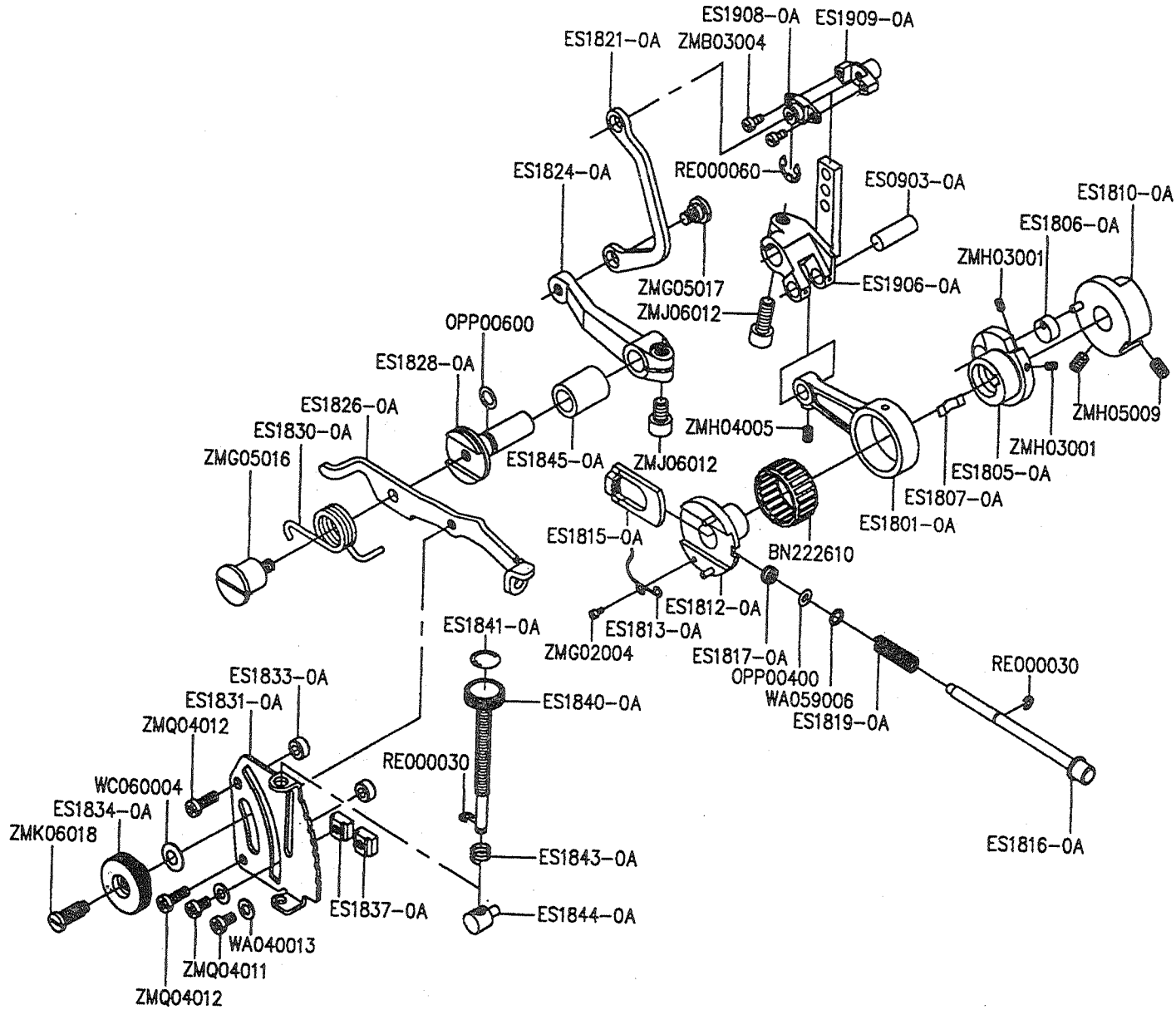

L. FEED MECHANISM

Part No.	Name of Part	Q'TY	Part No.	Name of Part	Q'TY
BN222610	NEEDLE BEARING -----	1	OPP00600	O RING -----	1
ES0903-0A	PIN -----	1	RE000030	E RING -----	1
ES1801-0A	CONNECTION -----	1	RE000060	E RING -----	1
ES1805-0A	ECCENTRIC -----	1	WA040013	WASHER -----	2
ES1806-0A	GUIDE/FEED ECCENTRIC	1	WA059006	WASHER -----	1
ES1807-0A	FLAT SPRING -----	1	WC060004	SPRING WASHER -----	1
ES1810-0A	REGULATOR -----	1	ZMB03004	SCREW (M3-0.5x5.7) -----	2
ES1812-0A	ECCENTRIC ASSEMBLY	1	ZMG02004	SCREW (M2-0.4x3) -----	1
ES1813-0A	SPRING -----	1	ZMG05016	SCREW (M5-0.8x8.4) -----	1
ES1815-0A	RATCHET -----	1	ZMG05017	SCREW (M5-0.8x5.5) -----	1
ES1816-0A	PUSH BUTTON -----	1	ZMH03001	SCREW (M3-0.5x4) -----	2
ES1817-0A	GASKET -----	1	ZMH04005	SCREW (M4-0.7x6) -----	1
ES1819-0A	SPRING -----	1	ZMH05009	SCREW (M5-0.8x5) -----	2
ES1821-0A	LINK -----	1	ZMJ06012	SCREW (M6-0.75x12) -----	2
ES1824-0A	LEVER -----	1	ZMK06018	SCREW (M6-1.0x17.7) -----	1
ES1826-0A	LEVER -----	1	ZMQ04011	SCREW (M4-0.7x6) 1-----	2
ES1828-0A	SHAFT -----	1	ZMQ04012	SCREW (M4-0.7x12) -----	2
ES1830-0A	SPRING -----	1			
ES1831-0A	REGULATOR PLATE -----	1			
ES1833-0A	SPACER -----	2			
ES1834-0A	NUT -----	1			
ES1837-0A	STOPPER -----	2			
ES1840-0A	ADJUSTING BAR -----	1			
ES1841-0A	SEAL -----	1			
ES1843-0A	SPRING -----	1			
ES1844-0A	PIN -----	1			
ES1845-0A	BUSHING -----	1			
ES1906-0A	CRANK -----	1			
ES1908-0A	CRANK PIN -----	1			
ES1909-0A	CRANK PIN -----	1			
OPP00400	O RING -----	1			

M. FEED MECHANISM

Consew 695EX/695HEX

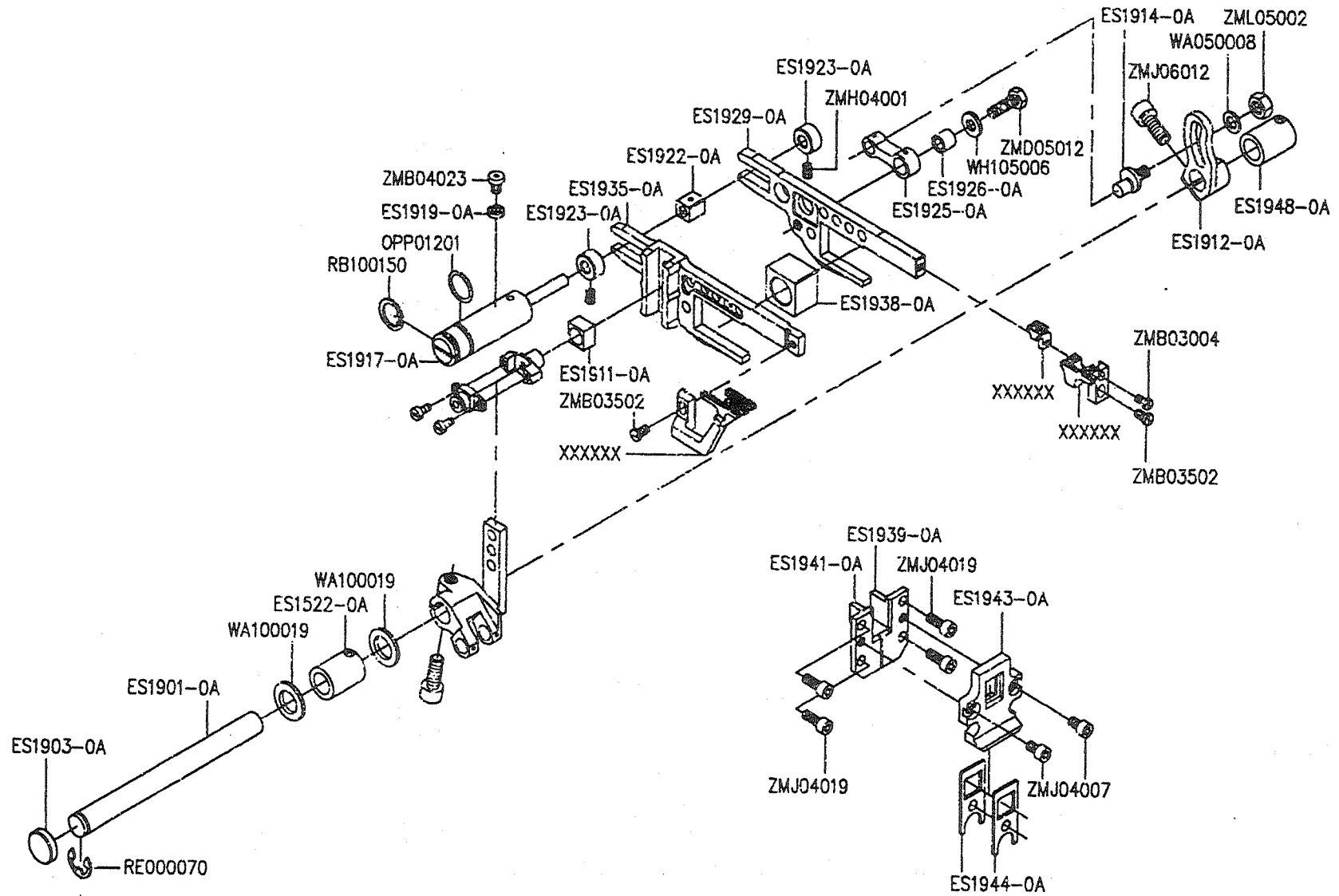

M. FEED MECHANISM

Part No.	Name of Part	Q'TY
ES1522-0A	BUSHING	1
ES1901-0A	SHAFT	1
ES1903-0A	PLUG	1
ES1911-0A	BLOCK	1
ES1912-0A	CRANK	1
ES1914-0A	PIN	1
ES1917-0A	PIN	1
ES1919-0A	GASKET	1
ES1922-0A	BLOCK	1
ES1923-0A	COLLAR	2
ES1925-0A	LINK	1
ES1926-0A	BUSHING	1
ES1929-0A	MAIN FEED BAR	1
ES1935-0A	DIFFERENTIAL FEED BAR	1
ES1938-0A	BLOCK	1
ES1939-0A	GUIDE/FEED BAR	1
ES1941-0A	GUIDE(LEFE)/FEED BAR	1
ES1943-0A	GUIDE/FEED BAR OIL SEAL	1
ES1944-0A	OIL SEAL	2
ES1948-0A	BUSHING	1
OPP01201	O RING	1
RB100150	C RING	1
RE000070	E RING	1
WA050008	WASHER	1
WA100019	WASHER	2
WH105006	WASHER	1
ZMB03004	SCREW (M3-0.5x5.7)	1
ZMB03502	SCREW (M3.5-0.6x8)	2
ZMB04023	SCREW (M4-0.7x6)	1
ZMD05012	SCREW (M5-0.8x13)	1
ZMH04001	SCREW (M4-0.7x4)	2
ZMJ04007	SCREW (M4-0.7x5)	2
ZMJ04019	SCREW (M4-0.7x8)	4
ZMJ06012	SCREW (M6-0.75x12)	1
ZML05002	NUT (M5)	1

N. KNIFE DRIVE MECHANISM

Consew 695EX/695HEX

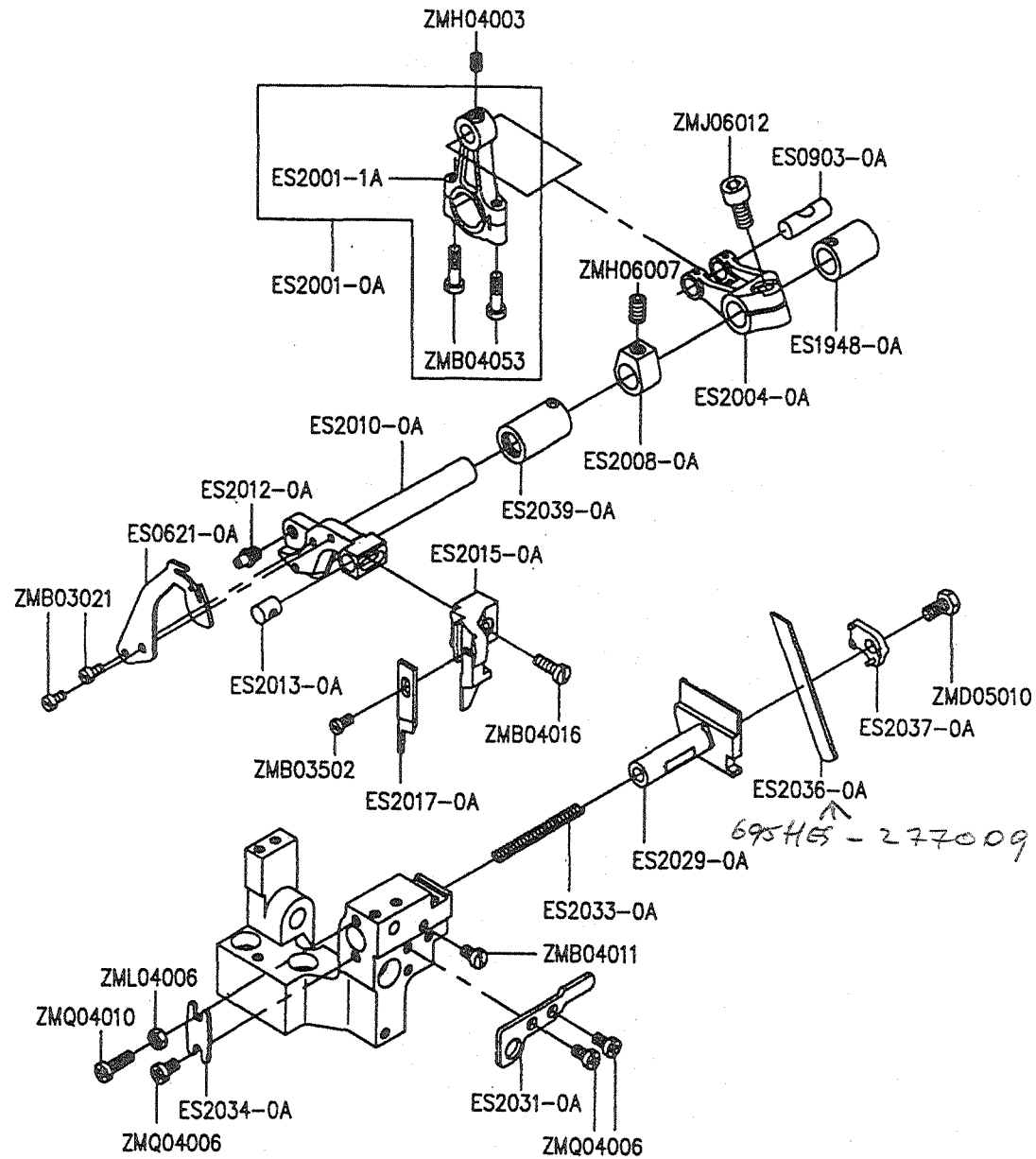

N. KNIFE DRIVE MECHANISM

Part No.	Name of Part	Q'TY
ES0621-0A	THREAD TAKEUP -----	1
ES0903-0A	PIN -----	1
ES1948-0A	BUSHING -----	1
ES2001-0A	CONNECTION -----	1
ES2001-1A	CONNECTION -----	1
ES2004-0A	CRANK -----	1
ES2008-0A	COLLAR -----	1
ES2010-0A	UPPER KNIFE LEVER -----	1
ES2012-0A	SCREW -----	1
ES2013-0A	PIN -----	1
ES2015-0A	UPPER KNIFE CLAMP -----	1
ES2017-0A	UPPER KNIFE -----	1
ES2029-0A	LOWER KNIFE HOLDER -----	1
ES2031-0A	GUIDE/LOWER KNIFE HOLDER ----	1
ES2033-0A	SPRING -----	1
ES2034-0A	PLATE -----	1
ES2036-0A	LOWER KNIFE/THICK -----	1
ES2037-0A	LOWER KNIFE CLAMP -----	1
ES2039-0A	BUSHING -----	1
ZMB03021	SCREW (M3-0.5x6.5) -----	2
ZMB03502	SCREW (M3.5-0.6x8) -----	1
ZMB04011	SCREW (M4-0.7x8) -----	1
ZMB04016	SCREW (M4-0.7x10) -----	1
ZMB04053	SCREW (M4-0.7x16) -----	2
ZMD05010	SCREW (M5-0.8x10) -----	1
ZMH04003	SCREW (M4-0.7x5) -----	1
ZMH06007	SCREW (M6-1.0x5) -----	1
ZMJ06012	SCREW (M6-0.75x12) -----	1
ZML04006	NUT (M4) -----	1
ZMQ04006	SCREW (M4-0.7x8) -----	3
ZMQ04010	SCREW (M4-0.7x16) -----	1

O. PRESSER FOOT MECHANISM

Consew 695EX/695HEX

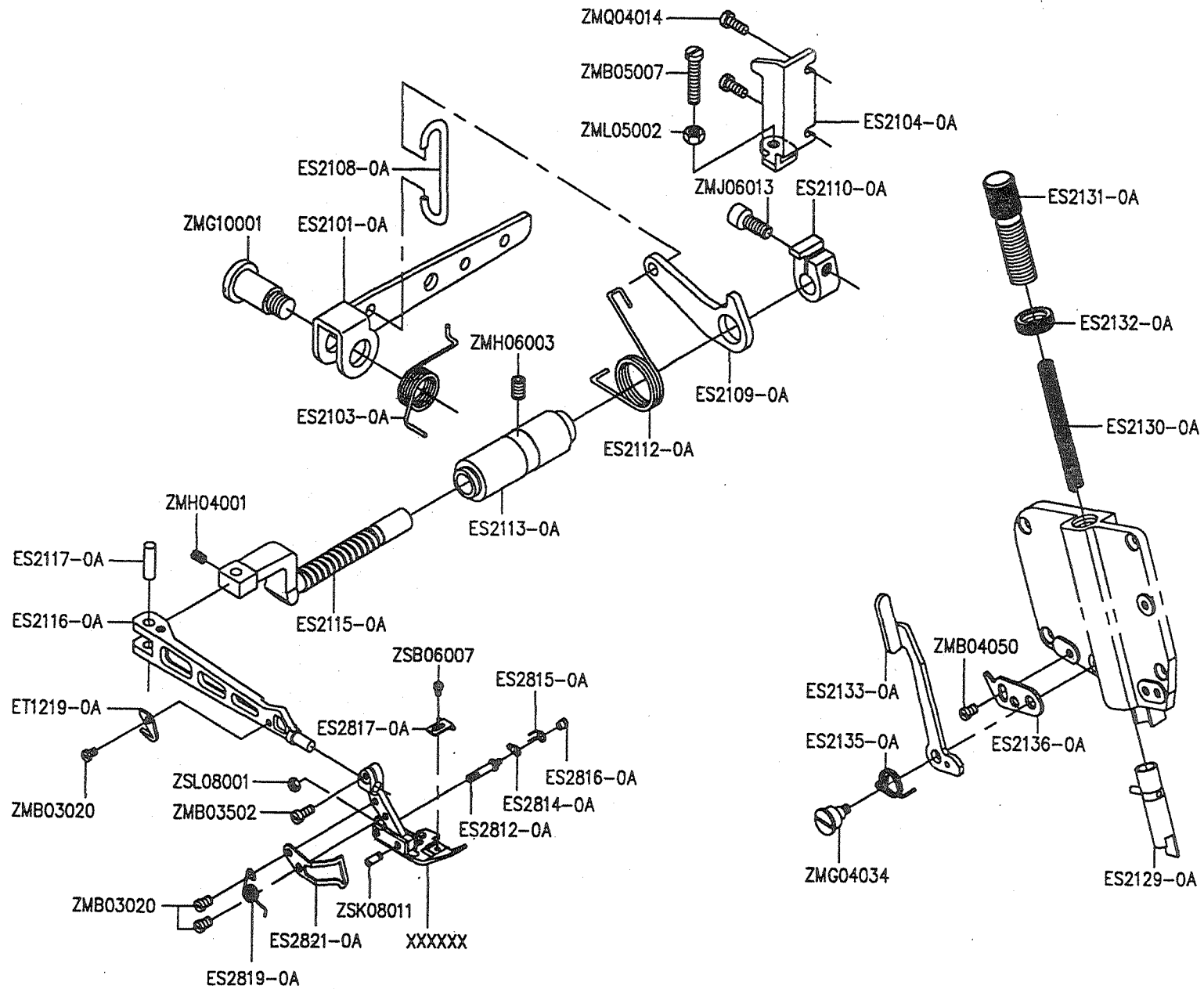

O. PRESSER FOOT MECHANISM

Part No.	Name of Part	Q'TY	Part No.	Name of Part	Q'TY
ES2101-0A	LEVER -----	1	ZMG10001	SCREW (M10-1.5x9) -----	1
ES2103-0A	SPRING -----	1	ZMH04001	SCREW (M4-0.7x4) -----	1
ES2104-0A	STOPPER -----	1	ZMH06003	SCREW (M6-1.0x8) -----	1
ES2108-0A	LINK -----	1	ZMJ06013	SCREW (M6-0.75x14) -----	1
ES2109-0A	LEVER -----	1	ZML05002	NUT (M5) -----	1
ES2110-0A	COLLAR -----	1	ZMQ04014	SCREW (M4-0.7x10) -----	2
ES2112-0A	SPRING -----	1	ZSB06007	SCREW (3/32-56x3) -----	1
ES2113-0A	BUSHING -----	1	ZSK08011	SCREW (1/8-44x8) -----	1
ES2115-0A	SHAFT -----	1	ZSL08001	NUT (1/8-44) -----	1
ES2116-0A	PRESSER ARM -----	1			
ES2117-0A	PIN -----	1			
ES2129-0A	PRESSER BAR -----	1			
ES2130-0A	SPRING -----	1			
ES2131-0A	ADJUSTING SCREW -----	1			
ES2132-0A	NUT -----	1			
ES2133-0A	LEVER -----	1			
ES2135-0A	SPRING -----	1			
ES2136-0A	STOPPER -----	1			
ES2812-0A	PIN -----	1			
ES2814-0A	LATCH -----	1			
ES2815-0A	SPRING -----	1			
ES2816-0A	NUT -----	1			
ES2817-0A	FABRIC GUARD -----	1			
ES2819-0A	SPRING -----	1			
ES2821-0A	FINGER GUARD -----	1			
ET1219-0A	CHAIN CUTTER -----	1			
ZMB03020	SCREW (M3-0.5x5) -----	3			
ZMB03502	SCREW (M3.5-0.6x8) -----	1			
ZMB04050	SCREW (M4-0.7x8) -----	1			
ZMB05007	SCREW (M5-0.8x25) -----	1			
ZMG04034	SCREW (M4-0.7x4) -----	1			

P. LUBRICATION MECHANISM *Consew 695EX/695HEX*

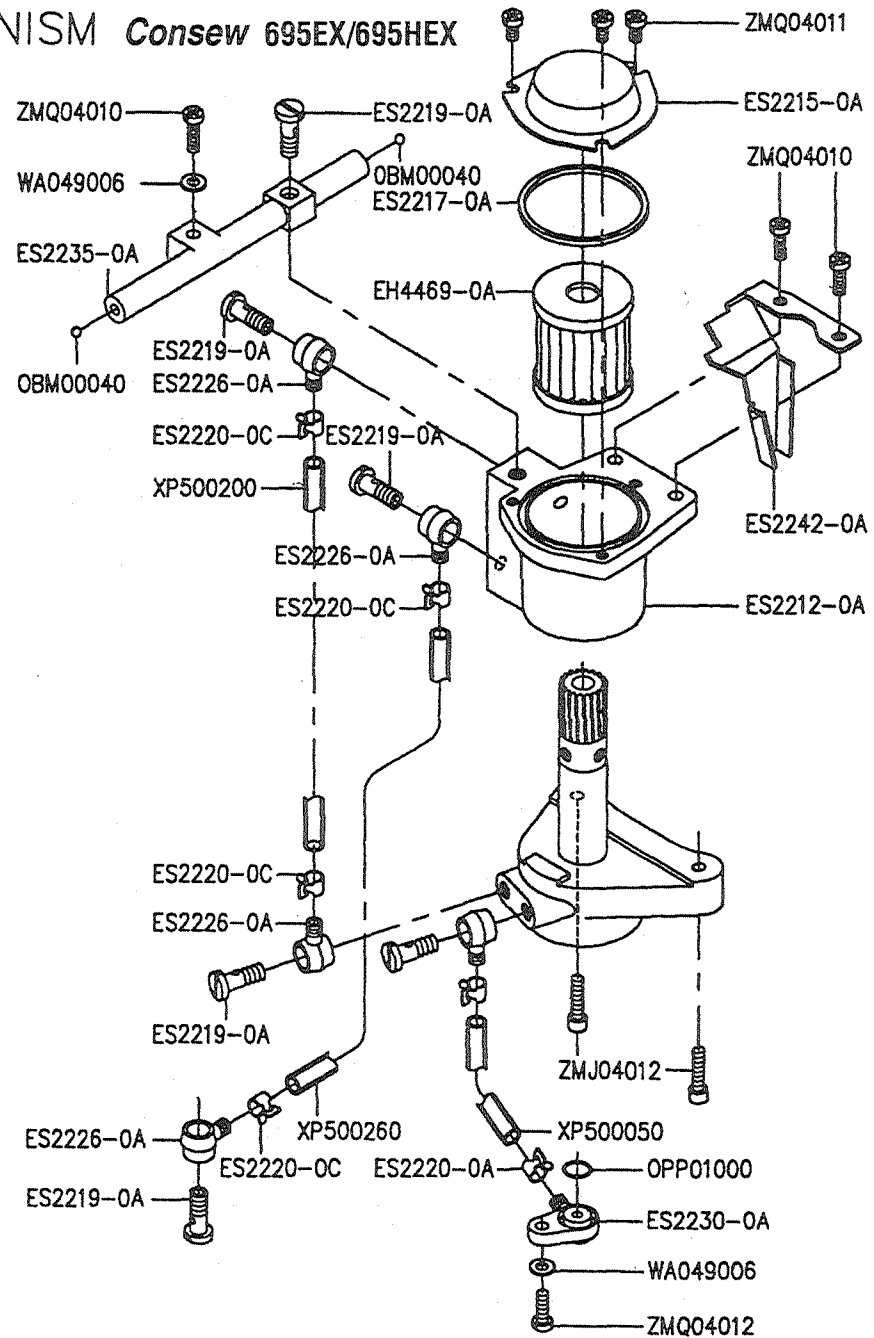
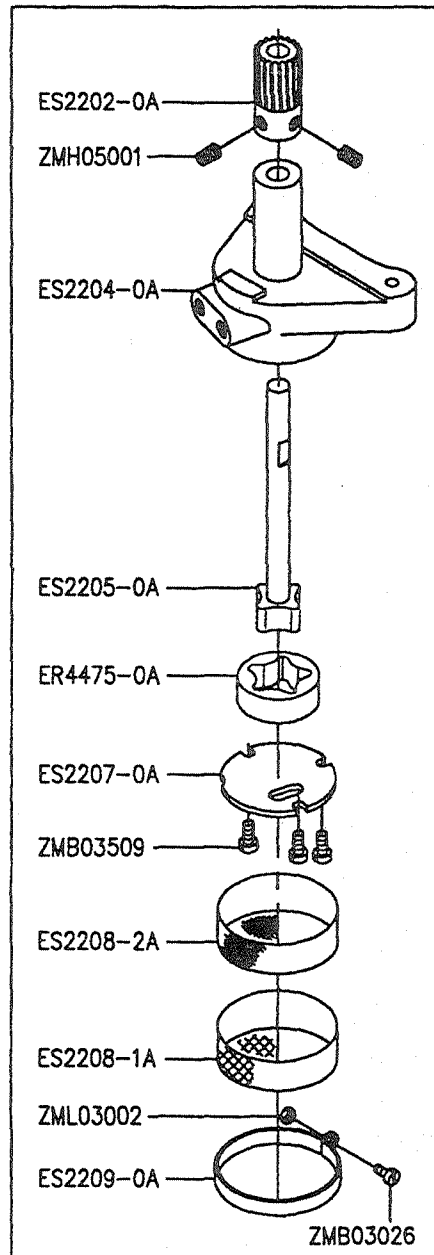

P. LUBRICATION MECHANISM

Part No.	Name of Part	Q'TY
EH4469-0A	OIL FILTER -----	1
ER4475-0A	ROTOR (OUTSIDE) -----	1
ES2202-0A	WORM WHEEL -----	1
ES2204-0A	PUMP BODY -----	1
ES2205-0A	ROTOR (INSIDE) SHAFT ---	1
ES2207-0A	CASING PLATE -----	1
ES2208-1A	FILTER -----	1
ES2208-2A	FILTER -----	1
ES2209-0A	GUIDE -----	1
ES2212-0A	TANK -----	1
ES2215-0A	COVER -----	1
ES2217-0A	O RING -----	1
ES2219-0A	SCREW -----	6
ES2220-0C	CLAMP -----	6
ES2226-0A	JOINT -----	1
ES2230-0A	JOINT -----	1
ES2235-0A	OIL DISTRIBUTOR -----	1
ES2242-0A	PLATE -----	1
OBM00040	PLUG -----	2
OPP01000	O RING -----	1
WA049006	WASHER -----	1
XP500050	TUBE -----	1
XP500200	TUBE -----	1
XP500260	TUBE -----	1
ZMB03026	SCREW (M3-0.5x8) -----	1
ZMB03509	SCREW (M3.5-0.6x6) -----	3
ZMH05001	SCREW (M5-0.8x5) -----	2
ZMJ04012	SCREW (M4-0.7x16) -----	2
ZML03002	NUT (M3) -----	1
ZMQ04010	SCREW (M4-0.7x16) -----	3
ZMQ04011	SCREW (M4-0.7x6) -----	3
ZMQ04012	SCREW (M4-0.7x12) -----	1

Q. LUBRICATION MECHANISM

Consew 695EX/695HEX

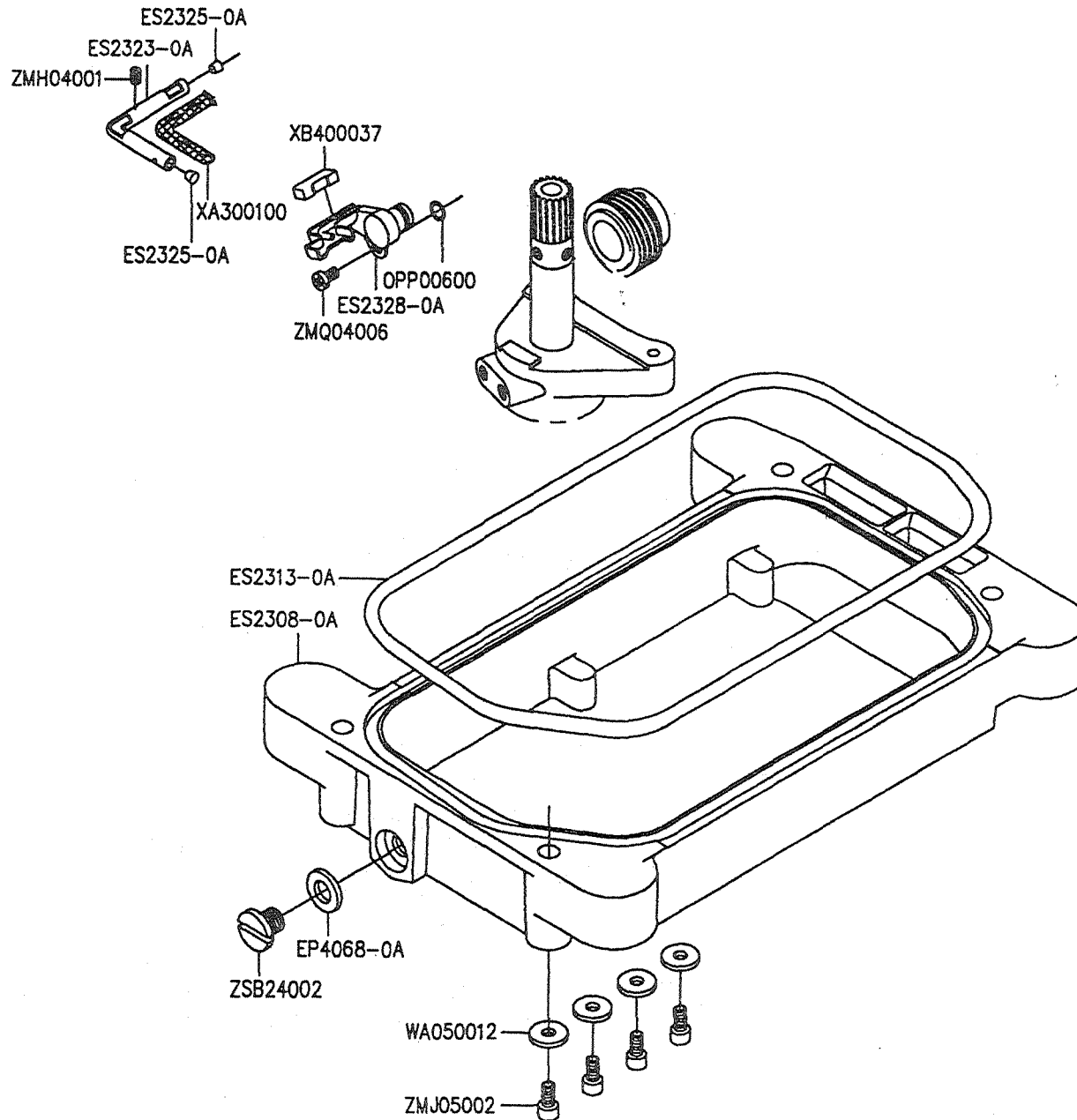

Q、CS-2500 給油機構 LUBRICATION MECHANISM

Part No.	Name of Part	Q'TY
EP4068-0A	DRAIN HOLE SEAL -----	1
ES2308-0A	OIL RESERVOIR -----	1
ES2313-0A	GASKET -----	1
ES2323-0A	PIPE -----	1
ES2325-0A	PLUG -----	2
ES2328-0A	JOINT -----	1
OPP00600	O RING -----	1
WA050012	WASHER -----	4
XA300100	OIL WICK -----	1
XB400037	FELT -----	1
ZMH04001	SCREW (M4-0.7x4) -----	1
ZMJ05002	SCREW (M5-0.8x12) -----	4
ZMQ04006	SCREW (M4-0.7x8) -----	1
ZSB24002	SCREW (3/8-24x8) -----	1

R. PARTS FOR SEMI-SUBMERGED INSTALLATION

Consew 695EX/695HEX

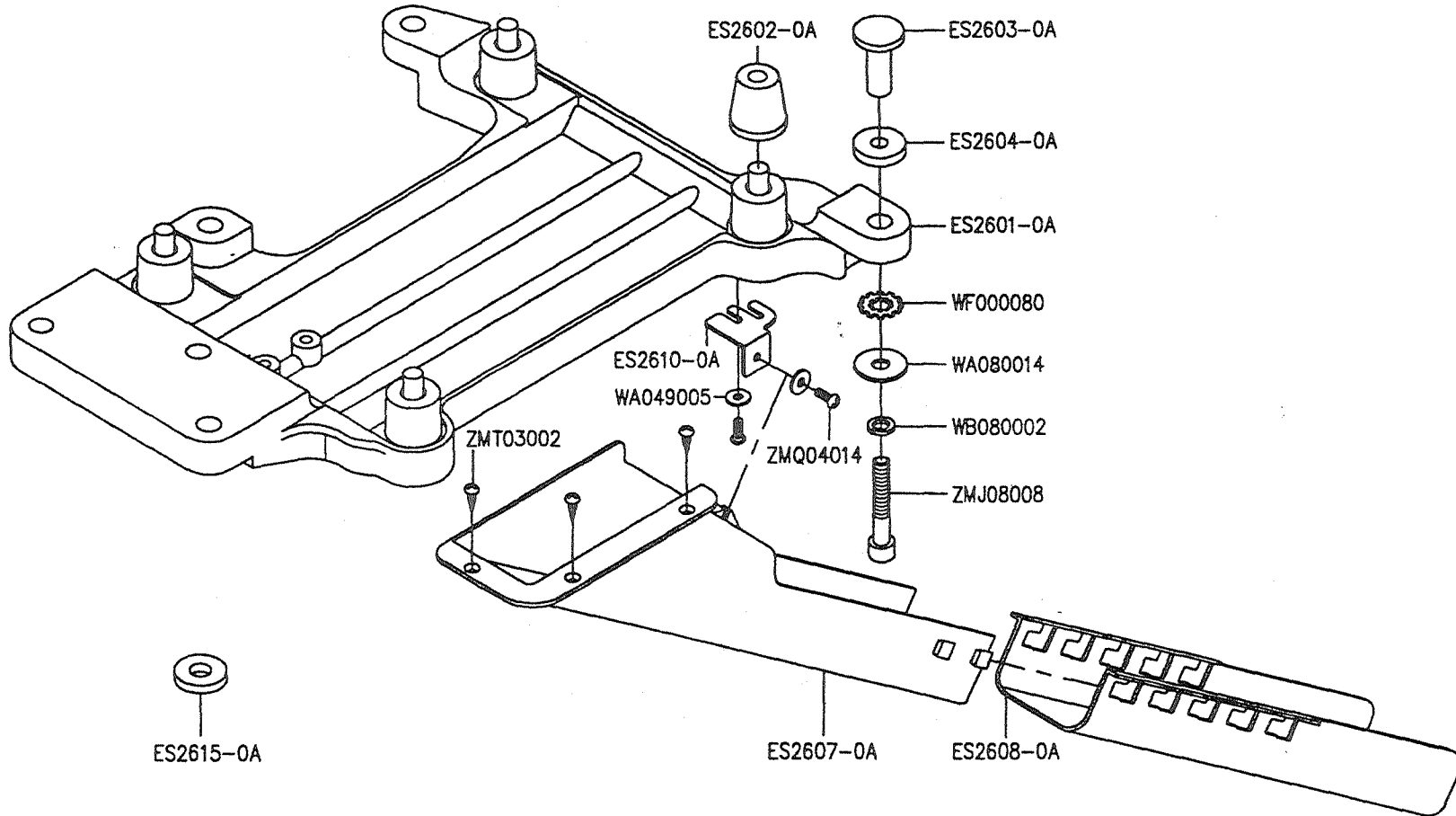

S. ACCESSORIES

Consew 695EX/695HEX

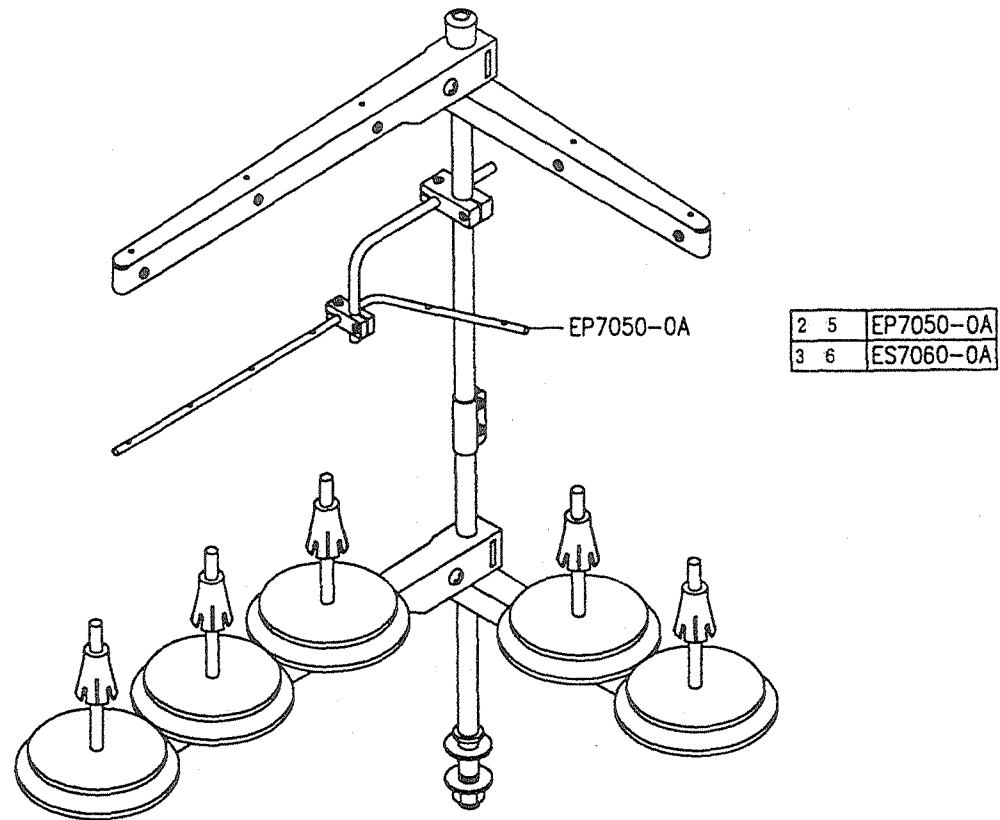

S. ACCESSORIES

Part No	Name of Part	Q'TY	Notes
EP7050-0A	THREAD STAND, COMPLETE SET	-- 1	3-6
ES7040-0A	THREAD STAND, COMPLETE SET	-- 1	2-5

T. NUMERICAL PARTS-LIST 1

PARTS NO.	PAGE	PARTS NO.	PAGE	PARTS NO.	PAGE	PARTS NO.	PAGE	PARTS NO.	PAGE
A1019-0A	2	ES0210-0A	4	ES0401-0A	10	ES0621-0A	28	ES1075-250A	14
BB6202VNN	10	ES0213-0A	4	ES0405-0A	10	ES0710-0A	14	ES1103-0A	14
BB6203	10	ES0215-0A	4	ES0407-0A	10	ES0711-0A	14	ES1219-0A	2
BB6203V	10	ES0216-0A	4	ES0412-0A	10	ES0713-0A	14	ES1223-0A	2
BN182208	20	ES0220-0A	4	ES0415-0A	10	ES0801-0A	8	ES1225-0A	2,4,6
BN222610	24	ES0221-0A	4	ES0416-0A	10	ES0802-0A	8	ES1226-0A	2
DC27#14	14	ES0225-0A	4	ES0418-0A	10	ES0803-0A	8	ES1306-0A	16
EH1021-0A	12	ES0227-0A	4	ES0419-0A	10	ES0805-0A	8	ES1307-0A	16
EH4469-0A	32	ES0231-0B	8	ES0422-0A	10	ES0807-0A	8	ES1313-0A	16
ES1015-0A	2	ES0232-0A	8	ES0424-0A	10	ES0809-0A	8	ES1314-0A	16
ES1018-0A	2	ES0235-0A	4	ES0425-0A	10	ES0813-0A	16	ES1315-0A	16
EP1025-0A	12	ES0301-0A	6,14	ES0430-0A	10	ES0814-0A	18	ES1320-0A	16
EP1057-0A	22	ES0302-2A	6	ES0433-0A	10	ES0901-0A	14	ES1323-0A	16
EP1283-0A	14	ES0303-0A	6	ES0501-0A	12	ES0901-1A	14	ES1327-0A	16
EP1361-0A	4	ES0309-0A	6	ES0502-0A	12	ES0903-0A	24,28	ES1328-0A	16
EP4068-0A	34	ES0316-0A	6	ES0503-0A	12	ES0905-0C	14	ES1332-0A	16
EP7050-0A	38	ES0318-0A	2	ES0504-0A	12	ES0908-0A	14	ES1336-0A	16
ER4475-0A	32	ES0320-0A	2	ES0507-0A	12	ES0912-0C	14	ES1341-0A	16
ES0108-0A	2	ES0322-0A	6	ES0509-0A	12	ES0915-0C	14	ES1343-0A	16
ES0109-0A	2	ES0324-0A	6	ES0510-0A	12	ES0918-0C	14	ES1501-0A	16,18
ES0111-0A	2	ES0325-0A	6	ES0513-0A	12	ES0919-0C	14	ES1501-1A	16,18
ES0113-0A	2	ES0326-0A	6	ES0514-0A	12	ES0923-0A	14	ES1504-0A	16,18
ES0116-0A	2	ES0326-1A	6	ES0601-0A	8	ES0925-0B	14	ES1508-0A	16,18
ES0117-0A	2	ES0331-0A	4	ES0603-0A	8	ES0926-0A	14	ES1516-0B	18
ES0201-0A	4	ES0334-0A	6	ES0606-0A	8	ES0927-0A	14	ES1519-0A	18
ES0203-0A	4	ES0336-0A	6	ES0608-0A	8	ES0928-0B	14	ES1522-0A	16,18,20,26
ES0206-0A	4	ES0339-0A	6	ES0610-0A	8	ES1016-01C	2	ES1601-0A	20
ES0207-0A	4	ES0352-0A	4	ES0614-0A	8	ES1075-230A	14	ES1603-0A	20

T. NUMERICAL PARTS-LIST 2

PARTS NO.	PAGE	PARTS NO.	PAGE	PARTS NO.	PAGE	PARTS NO.	PAGE	PARTS NO.	PAGE
ES1607-0A	0	ES1815-0A	24	ES1922-0A	26	ES2039-0A	28	ES2217-0A	32
ES1611-0A	20	ES1816-0A	24	ES1923-0A	26	ES2101-0A	30	ES2219-0A	32
ES1613-0A	20	ES1817-0A	24	ES1925-0A	20,26	ES2103-0A	30	ES2220-0C	2,32
ES1614-0A	20	ES1819-0A	24	ES1926-0A	20,26	ES2104-0A	30	ES2226-0A	32
ES1616-0A	20	ES1821-0A	24	ES1929-0A	26	ES2108-0A	30	ES2230-0A	32
ES1622-0A	20	ES1824-0A	24	ES1935-0A	26	ES2109-0A	30	ES2235-0A	32
ES1626-0B	20	ES1826-0A	24	ES1938-0A	26	ES2110-0A	30	ES2242-0A	32
ES1628-0A	20	ES1828-0A	24	ES1939-0A	26	ES2112-0A	30	ES2308-0A	34
ES1701-0A	22	ES1830-0A	24	ES1941-0A	26	ES2113-0A	30	ES2313-0A	34
ES1703-0A	22	ES1831-0A	24	ES1943-0A	26	ES2115-0A	30	ES2314-0A	10
ES1705-0A	22	ES1833-0A	24	ES1944-0A	26	ES2116-0A	30	ES2317-0A	2
ES1708-0A	22	ES1834-0A	24	ES1948-0A	18,20,26,28	ES2117-0A	30	ES2319-0A	2
ES1709-0A	22	ES1837-0A	24	ES2000-0A	6	ES2129-0A	30	ES2323-0A	34
ES1710-0A	22	ES1840-0A	24	ES2001-0A	28	ES2130-0A	30	ES2325-0A	34
ES1711-0A	22	ES1841-0A	24	ES2001-1A	28	ES2131-0A	30	ES2328-0A	34
ES1712-0A	22	ES1843-0A	24	ES2004-0A	28	ES2132-0A	30	ES2341-0A	2
ES1714-0A	22	ES1844-0A	24	ES2008-0A	28	ES2133-0A	30	ES2401-0A	2
ES1716-0A	22	ES1845-0A	24	ES2010-0A	28	ES2135-0A	30	ES2402-0A	2
ES1718-0A	22	ES1901-0A	26	ES2012-0A	28	ES2136-0A	30	ES2407-0A	2
ES1720-0A	22	ES1903-0A	2,26	ES2013-0A	28	ES2202-0A	32	ES2409-0A	2
ES1721-0A	22	ES1906-0A	24	ES2015-0A	28	ES2204-0A	32	ES2410-0A	2
ES1801-0A	24	ES1908-0A	24	ES2017-0A	28	ES2205-0A	32	ES2420-0A	2
ES1805-0A	24	ES1909-0A	24	ES2029-0A	28	ES2207-0A	32	ES2421-0A	2
ES1806-0A	24	ES1911-0A	26	ES2031-0A	28	ES2208-1A	32	ES2426-0A	2
ES1807-0A	24	ES1912-0A	26	ES2033-0A	28	ES2208-2A	32	ES2601-0A	36
ES1810-0A	24	ES1914-0A	26	ES2034-0A	28	ES2209-0A	32	ES2602-0A	36
ES1812-0A	24	ES1917-0A	26	ES2036-0A	28	ES2212-0A	32	ES2603-0A	36
ES1813-0A	24	ES1919-0A	26	ES2037-0A	28	ES2215-0A	32	ES2604-0A	36

T. NUMERICAL PARTS-LIST 3

PARTS NO.	PAGE	PARTS NO.	PAGE	PARTS NO.	PAGE	PARTS NO.	PAGE	PARTS NO.	PAGE
ES2607-0A	36	OPP04000	10	WH205003	16, 18	ZMB03026	32	ZMD05012	20, 26
ES2608-0A	36	RE100150	26	XA300015	2	ZMB03030	14	ZMD05013	18, 20
ES2610-0A	36	RE000030	24	XA300030	16	ZMB03031	18	ZMD06009	14, 16
ES2615-0A	36	RE000060	24	XA300100	34	ZMB03502	26, 28, 30	ZMG02003	14
ES2812-0A	30	RE000070	26	XA300120	2	ZMB03504	16	ZMG02004	24
ES2814-0A	30	RE000080	14	XE123001	12	ZMB03507	2	ZMG04032	6
ES2815-0A	30	WA030001	4, 8	XE308007	14	ZMB03509	18, 20, 32	ZMG04033	4, 22
ES2816-0A	30	WA039001	18	XE308008	2	ZMB04007	8, 22	ZMG04034	30
ES2817-0A	30	WA040013	24	XE312004	16	ZMB04011	8, 22, 28	ZMG05016	24
ES2819-0A	30	WA040014	2	XE400036	16	ZMB04014	2	ZMG05017	24
ES2821-0A	30	WA040016	6	XE400037	34	ZMB04016	6, 10, 28	ZMG10001	30
ES6004-0A	18	WA049005	6, 36	XF400039	2	ZMB04023	26	ZMH03001	4, 24
ES6006-0A	2	WA049006	32	XF400037	2	ZMB04031	6	ZMH03002	14, 22
ES6007-0A	2	WA050008	26	XF500050	32	ZMB04050	8, 30	ZMH03006	16
ES6008-0A	2	WA050011	20	XF500200	32	ZMB04053	14, 16, 18, 28	ZMH03007	4
ES6018-0A	20	WA050012	34	XF500260	32	ZMB04054	16	ZMH03501	10
ES7060-0A	38	WA059006	24	YA041200	4	ZMB05007	30	ZMH04001	2, 4, 8, 14,
ET1219-0A	30	WA080014	36	YA070100	2	ZMB06015	4		26, 30, 34
OAGM101503	20	WA100019	16, 26	YD050010	2	ZMC02003	14	ZMH04003	6, 14, 28
OATC101904	16, 18	WA120002	14	YD050014	2	ZMC02505	16	ZMH04005	24
OBM00040	2, 32	WE041002	6	YD050018	2	ZMC03009	16, 18	ZMH04009	14
OPP00400	24	WE051001	16, 18, 20	ZMB02505	16	ZMC04004	10	ZMH05001	10, 14, 18, 32
OPP00401	20	WE060002	10	ZMB03001	8, 16, 22	ZMC04007	2	ZMH05004	10
OPP00600	24, 34	WE080002	36	ZMB03004	2, 24, 26	ZMC04010	2, 4	ZMH05009	10, 24
OPP01000	32	WC060004	24	ZMB03011	10	ZMC04011	4	ZMH06003	10, 30
OPP01201	14, 26	WF000080	36	ZMB03020	4, 14, 30	ZMD03001	18	ZMH06007	28
OPP01700	10	WC000006	4, 6, 22	ZMB03021	28	ZMD04007	6	ZMJ04007	26
OPP03150	10	WH105006	20, 26	ZMB03025	4	ZMD05010	16, 18, 28	ZMJ04012	32

T. NUMERICAL PARTS-LIST 4

PARTS NO.	PAGE	PARTS NO.	PAGE
ZMJ04019	26		
ZMJ05002	20,34		
ZMJ06002	16		
ZMJ06010	10		
ZMJ06012	14,16,18, 20,24,26,28	ZSB06007 ZSB24002	30 34
ZMJ06012	16	ZSK08011	30
ZMJ06013	30	ZSL08001	30
ZMJ06015	2		
ZMJ08008	36		
ZMK06018	24		
ZMK06019	10		
ZML03002	32		
ZML04006	28		
ZML05002	26,30		
ZMQ04006	4,28,34		
ZMQ04010	4,28,32		
ZMQ04011	2,4,6,24, 32		
ZMQ04012	2,4,8, 24,32		
ZMQ04013	4		
ZMQ04014	2, 8,10, 22,30,36		
ZMT03002	36		

Parts Manual for Models 695EX & 695HEX



Main Office
131 West 25th Street
New York, NY 10001
Tel: 212-741-7788
Fax: 212-741-7787

Miami Branch Office
7855 N.W. 29th St. (#166)
Miami, FL 33122
Tel: 305-471-0200
Fax: 305-471-0243

West Coast Branch Office
1400 South Broadway
Los Angeles, CA 90015
Tel: 213-745-8844
Fax: 213-745-8855

e-mail: consew@worldnet.att.net

web: www.consew.com

